

Ver. 001 Ed. 08.2022

**AUTHORISED DEALER**

**USE AND MAINTENANCE MANUAL**



## CONTENTS

<b>1.</b>	<b>Delivery and warranty</b>	<b>5</b>
1.1	Introduction	
1.2	Storing and using this manual	
1.3	Warranty	
1.4	General warnings and manufacturer's liability limits	
1.5	Machine description	
1.6	Intended use	
1.7	Improper use	
1.7.1	Safety rules	
1.7.2	Lighting	
1.8	Specific equipment details	
1.8.1	Warning and danger signs	
<b>2.</b>	<b>Technical specifications</b>	<b>9</b>
2.1	Main parts	
2.2	Technical characteristics	
2.3	Machine dimensions and weight	
2.4	Wiring diagram	
<b>3.</b>	<b>Factory testing, shipping, delivery and installation</b>	<b>12</b>
3.1	Factory testing	
3.2	Delivery and handling	
3.3	Installation	
3.3.1	Disposal of packaging	
3.4	Connections	
3.5	Electrical connections	
3.5.1	220 V 50 Hz single-phase machine	
<b>4.</b>	<b>Using the machine</b>	<b>14</b>
4.1	Control key	
4.2	Programme menu	
4.3	User menu	
4.3.1	Oil heating and cleaning	
4.3.2	Vacuum management	
4.3.3	Wi-Fi	
4.3.4	Language	
4.4	Vacuum packing	
4.5	Packing of liquid or semi-liquid products	
4.6	Packing products using the inclined profile supplied	
4.7	Cleaning the machine	
4.8	Machine in stand-by	
4.9	Alarms	
<b>5.</b>	<b>Checks and maintenance</b>	<b>20</b>
5.1	Checks and maintenance	
5.2	Maintenance	
5.2.1	Vacuum pump	

6.	<b>Obligations in case of malfunctions and/or potential hazards</b>	21
6.1	User obligations	
7.	<b>Troubleshooting</b>	21
7.1	Troubleshooting	
7.2	WEEE (Waste Electrical and Electronic Equipment)	

## 6 - Obligations in case of malfunctions and/or potential hazards

The operators are obliged to signal to their line managers any deficiency and/or potentially hazardous situation that should arise.

### 6.1 - User obligations

The user is obliged to timely inform the manufacturer if any defects and/or malfunctions emerge on the accident-prevention systems, and on any other potentially dangerous situation of which it may come to know.

The user and/or third parties (excluding the manufacturer's duly authorised personnel) are strictly forbidden from making changes of any type and entity to the machine and its functions, as well as to this technical document. In the event of malfunctions and/or dangers due to failure to comply with that stated above, the manufacturer declines all responsibility for the resulting consequences. We suggest requesting any changes directly to the manufacturer.

## 7 - Troubleshooting

### 7.1 - Troubleshooting

Problems	Solutions
After pressing the main switch the machine fails to start	Verify that the plug is properly inserted into the power outlet and check the internal contacts of the plug itself, where required
The machine works properly, but when the cover is re-opened the package is not sealed	Lift the Teflon and check that the heating element does not have any interruptions and that it is secured to the side clamps

### 7.2 - WEEE (Waste Electrical and Electronic Equipment) regulations



The crossed-out wheellie bin symbol on the equipment or on its packaging indicates that the product must be disposed of separately from other waste at the end of its useful life. The separate waste collection of this device at the end of its life is organised and managed by the manufacturer. The user who wishes to dispose of this device must contact the manufacturer and follow the given instructions to ensure that the separate waste collection procedure is observed at the end of the equipment's useful life.

The correct disposal of the device for the subsequent recycling, management and treatment of its parts in an environment-friendly way helps to prevent possible adverse effects on the environment and promotes the reuse and/or recycling of its constituent materials.

**Unlawful disposal of the product by the user shall imply the application of administrative penalties under current law.**

## 5 - Checks and maintenance

### 5.1 - Checks and maintenance

The machine's internal mechanism must be accessed exclusively by our specialised technician. If anybody else accesses the inside of the machine on their own initiative, the manufacturer declines all civil and criminal liability for any accidents to people and damages caused to objects. All electrical components are protected inside the machine body and can only be accessed by unscrewing the protective guard: to access the inside, pull the plug out of the electrical panel.

### 5.2 - Maintenance

1. Clean the sealing bar and the silicone counter-bar every 15 days using methylated spirits.
2. Change the oil as during the initial start-up setting.  
For Easy models, as set by the manufacturer, the display will show the "**change oil**" message after every 2,000 cycles.  
The user must contact the dealer, who will check the efficiency of the oil and replace it if necessary.
3. Replace the heating element, Teflon, sealing bar and the seals of the cover roughly every 200 hours of operation.
4. Replace the silicone counter-bar roughly every 100 hours of operation.
5. Check the pump vane, filters and the tightness of the pneumatic solenoid valves roughly every 35,000 hours of operation.

#### 5.2.1 - Vacuum pump

To protect the vacuum pump and prolong its service life, strictly observe the following instructions:

- Do not suck up water vapour, liquids or any type of flour. This will deteriorate the pump oil's viscosity and damage the pump itself.
- Periodically check the level of the pump oil through the oil level indicator.
  - a level below the minimum can damage the pump
  - a level above the maximum can damage the pump filter and the pump itself
- Periodically check the colour of the pump oil.  
If the oil appears cloudy, dark or emulsified, it must be replaced immediately.
- Replace the pump oil every 2 / 4 / 6 or 12 months depending on use and the appliance's location, or when the "**change oil**" message appears on the display.  
It may even be necessary to change the pump oil every month.
- **Replace the pump oil before an extended shutdown.**

**WARNING!!** Given that the vacuum packing machine is almost always installed in the kitchen, an environment dense with water vapour and humidity, the level and quality of the pump oil must be checked constantly and the oil replaced frequently and regularly.

## 1 - Delivery and warranty

### 1.1 - Foreword

**WARNING!** *The symbols used in this manual draw the reader's attention to points and operations that are hazardous to the operator's personal safety or that risk damaging the machine. Do not use the machine unless you have read and properly understood these notes.*

#### **WARNING!**

*For reasons of clarity, some of the illustrations appearing in this manual show the machine or parts of it with its panels or guards removed.  
Never use the machine in this condition; only use it when it is fully equipped with the guards and in good working order.*

The manufacturer forbids the reproduction, even partial, of this manual or the use of its contents for purposes other than those expressly allowed.  
Any breach in this regard shall be punishable by law.

### 1.2 - Storing and using this manual

This manual uses text and illustrations to familiarise users with the machine and explain the instructions and essential criteria for its transport, handling, use and maintenance.

Read this manual carefully before using the machine.

Store this manual with care near the machine so that it can be readily available for future reference.

If the manual is lost or damaged, you can request a copy from your dealer or directly from the manufacturer.

If the machine is transferred to a new owner, the latter's identification and contact details must be notified to the manufacturer.

The manual reflects the state of knowledge at the time of sale of the machine, and cannot be considered inadequate in the light of more recent experience and updates. The manufacturer reserves the right to update the products and manuals without being obliged to update previous products and manuals, except in exceptional circumstances.

In case of doubt, contact your local service centre or the manufacturer.

The manufacturer is committed to continuously improving its products.

To this end, the manufacturer is glad to receive any reports or proposals relating to the improvement of the machine and the manual.

The machine is delivered to the customer with the warranty conditions applicable at the time of sale.

Please contact your dealer for any further information.

### 1.3 - Warranty

The manufacturer undertakes to guarantee to the customer or to the dealer, for the duration of 12 (twelve) months from the date of shipment and direct delivery of the product, the integrity and efficient operation of the components relative to the machine.

The warranty does not cover all parts of the machine subject to normal wear, nor components for which use generates constant and unrelenting wear:

- A. Heating elements - Teflon - seals - bell opening pistons - sealing membrane - air filters - oil filters - oil change - pump vane.
- B. If the manufacturer receives a vacuum pump relative to a machine under warranty for suction-related issues and malfunctions, the manufacturer reserves the right to check whether any foreign bodies (liquids, solids, sauces, condiments, etc.) were sucked up; if this is the case, material repairs and labour will be charged as the problem is not due to manufacturing defects, but to the Customer's negligence during use.
- C. Any problems involving the electronic circuit boards must be inspected by the manufacturer before the replacement part is shipped under warranty. Power surges, overvoltage and disturbances on the external network could cause damages not ascribable to the manufacturer and the product's sound construction.
- D. Any problems linked to pneumatic, structural and mechanical parts will be regularly resolved within the warranty terms without any charge whatsoever.
- E. During the warranty's validity period, for interventions covered by warranty, the replaced materials will not be charged, while the labour costs will.  
During the warranty's validity period, for interventions that for various reasons are not covered by the warranty, the costs for replaced materials and labour will be charged.
- F. If any external interventions by our technicians are requested during the warranty period, the transfer costs (there and back) will be charged fully regardless of the reason for the intervention.

### 1.4 - General warnings and manufacturer's liability limits

Every man-machine interaction in the context of the machine's intended use and along its entire life has been carefully and thoroughly analysed by the manufacturer during the design, construction and instruction manual drafting phases. Nevertheless, nothing can replace the experience, adequate training and, above all, "common sense" of the people who interact with the machine. These requirements are deemed indispensable both during every operating phase of the machine and when reading this manual.

Failure to observe the precautions or specific warnings given in this manual and use of the machine by inadequate personnel breach all the safety rules concerning the design, construction and intended use of the supply and releases the manufacturer from any responsibility in case of harm to people or damage to objects.

**The manufacturer therefore shall not be held liable for any consequences stemming from the user's failure to observe the safety precautions given in this manual.**

The operator can stop the cycle before it ends by pressing ON.

**N.B.: this operation must be performed strictly with the suction cap closed.**

#### 4.10 - Alarms

##### OIL CHANGE

C H A N G E P U M P	3 0
O I L	

If the number of cycles for the oil change is reached during the job, the display will show the message "**CHANGE PUMP OIL**", inviting the user to change the pump oil.

The machine will stop and this message will remain visible for 10 seconds, to allow the operator enough time to read it. The display will then return to the previous situation/screen (same programme that was being used).

If the machine is switched off, the message "**CHANGE PUMP OIL**" will appear for 30 seconds then the machine will start normally.

If the machine is used for a further 200 cycles, it will stop and the message "**CHANGE PUMP OIL**" will appear for 60 seconds then the machine will start normally.

O I L H E A T I N G C Y C L
I m m e d i a t e l y

##### OIL CLEANING CYCLE

Once the limit of cycles is reached, the message "**OIL HEATING CYCLE**" will appear: select **Immediately** and press ON  to proceed.

The following instructions will appear on the display:

"Close black plug or chamber lid and press ON. 

R E A D Y T O U S E
T h a n k y o u !

The message "**READY TO USE Thank you!**" will appear.

The machine will automatically return to the situation preceding the alarm.

The oil heating cycle can be stopped by pressing ON  while it is running, but it will not be considered completed.

O I L H E A T I N G C Y C L
I m m e d i a t e l y

The oil cleaning cycle can be postponed when the message appears.

O I L H E A T I N G C Y C L
P o s t p o n e

To modify it press the LH arrow.  **Immediately** will start flashing.

Use the UP  and DOWN  arrows to select **Postpone**.

Wait 5 seconds or press the LH arrow  to confirm.

The selection will stop flashing.

A new message will remind the user to perform the operation after 50 cycles.

#### 4.7 - Cleaning the machine

**WARNING! Disconnect the machine from the mains power supply before cleaning it.**

Do not clean the machine using a water jet.

Only use non-toxic detergents specifically formulated for cleaning components used with foodstuffs. Do **NOT** use detergents containing chloride.

Do **NOT** use ethyl alcohol to clean the cover.

It can be cleaned regularly using a soft damp cloth wetted with cold or lukewarm water, with a slight addition of neutral detergent.

We recommend avoiding:

- The use of products containing: denatured ethyl alcohol, solvents in general, benzene, trichloroethylene.
- The use of abrasive materials and contact with sharp objects.

**Drying:** Once the cover has been cleaned, it can be dried with slightly dampened chamois leather, without rubbing.

To facilitate cleaning operations, it is possible to remove the side panels to easily reach all points of the vacuum chamber.

To remove the sides, proceed as follows:

- Unscrew the knobs "3"
- Remove the sides "1" and "2" taking care not to lose the gasket "4"
- Carry out cleaning operations
- Reassemble everything taking care to tighten the knobs well.

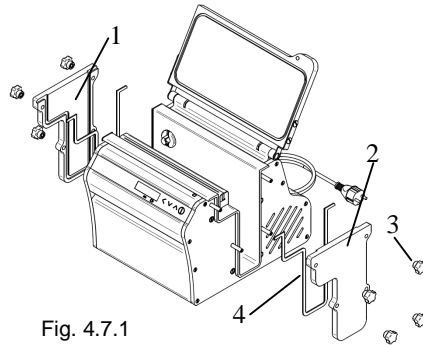

Fig. 4.7.1

**ATTENTION! Before tightening the knobs, make sure that the sides are correctly assembled. The gasket must be level with the aluminum top.**

#### 4.8 - Machine in stand-by

**WARNING!** If the machine is not used for extended periods of time, to prevent dirt or dust from building up inside the chamber, we suggest closing the bell and fastening it with the bell fixing knob.

If the machine is not expected to be used for more than one week, before it is taken out of service the oil should be replaced, even if this was already done recently.

#### 4.9 - Vacuum pump heating

During winter we suggest pre-heating the pump briefly in the morning to fluidify the oil before it starts circulating:

- Put the main switch to ON.
- Close the lid (as shown on the display)
- Press the UP button 3 times.

The machine will run the oil heating cycle until it reaches the time, then it will stop automatically.

#### 1.5 - Machine description

The vacuum packing machines we manufacture are state-of-the-art and feature an interchangeable modular board with fully electronic controls, which are therefore not subject to wear. The electronically controlled sealing unit consists of a stainless-steel bar with flat heating element (5 mm) which, thanks to the excellent pneumatic system installed, guarantees balanced and uniform sealing on any type of bag used (nylon, polyethylene, Cryovac).

The vacuum pumps adopted are highly up-to-date and guarantee, along with an extremely high degree of final vacuum, an astonishingly low level of noise despite working with uninterrupted cycles.

The models appearing in this manual are manufactured in conformity to **UL and CSA norms** and subsequent amendments.

If any accident occurs, the manufacturer shall not be held liable if the machine has been modified, tampered with, had its safety guards removed or is used for purposes other than the intended use specified by the manufacturer.

#### 1.6 - Intended use

The machine is designed and manufactured for vacuum packing of products according to the instructions given in this manual and must be used solely for this purpose. Any other use must be regarded as improper and thus dangerous. The manufacturer shall not be held liable for any damages deriving from improper, incorrect and unreasonable use. The machine must be used in a professional setting by qualified operators who work in the sector and have read and understood this manual.

#### 1.7 - Improper use

##### 1.7.1 - Safety rules

The following points should be observed in particular:

1. avoid touching metal parts of the machine with wet or damp hands;
2. do not pull the power cord or the appliance itself to detach it from the power outlet;
3. do not allow children or personnel lacking proper training from using the packing machine;
4. electrical safety is only ensured when the appliance is properly connected to an efficient earthing device, as specified in the applicable electrical safety regulations; this essential requirement must be verified and, in case of doubts, a thorough inspection of the system by professionally qualified personnel must be requested; the manufacturer shall not be held liable for any damages caused by the absence of an earthing system;
5. if the earthing system is potentially damaged, the machine must be put out of service so as to prevent undesired and/or involuntary activations;
6. always use protective fuses conforming to the safety regulations in force, having the correct value and with suitable mechanical characteristics;
7. keep the cord far away from hot parts;
8. always switch the machine off and disconnect it from the mains power supply before starting general cleaning operations or washing;
9. clean the machine's coatings, panels and controls using soft cloths either dry or slightly wetted with a mild detergent or methylated spirits solution;

### 1.7.2 - Lighting

The packing machine must be installed in a place that ensures adequate natural and artificial lighting as required by local regulations.

In any case, the lighting must be uniform and ensure good visibility of every part of the machine and must not generate dangerous reflections. The lighting must ensure clear reading of the control panels and the emergency buttons must be clearly identifiable.

### 1.8 - Specific equipment details

Citing the "Model", "Serial number" and "Year of manufacture" of the machine will help our technical assistance service to respond to your requests rapidly and effectively. We recommend specifying the machine model and serial number whenever you contact the technical assistance service.

This information appears on the rating plate shown in Fig. 1.8.1.

As a reminder, we suggest writing the data of the machine you have purchased in the table below.

Packing machine model.....
Serial no.....
Year of manufacture.....
Type.....

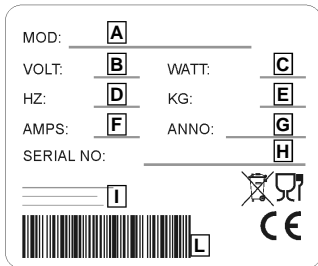

- A = Model
- B = Power supply
- C = Motor power
- D = Motor frequency Hz
- E = Weight
- F = Amperage
- G = Year of manufacture
- H = Serial no.
- I = Manufacturer
- L = Barcode

Fig. 1.8.1

### 4.4 - Vacuum packing

- Connect the machine to the mains power supply.
- Power the machine by pressing the switch on the right-hand side. The display will switch on showing the main screen.
- Press the ON button.
- Use the UP and DOWN buttons to scroll through the list of pre-set programmes.
- Put the bag on the vacuum chamber by placing the open side on the sealing bar so that it lies perfectly flat.
- Lower the cover by applying a certain amount of pressure so that it stays closed and the processing cycle can start.

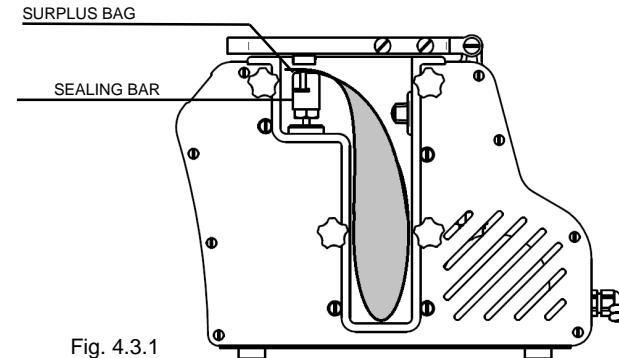

Fig. 4.3.1

### 4.5 - Packing of liquid or semi-liquid products

With our vacuum packing machines it is possible to vacuum-pack liquid or semi-liquid products (soups, sauces, condiments, etc.), extending their life and preserving their flavours and hygiene. In these cases, it is important to remember that the bags must never be filled all the way but only to 50% of their capacity, taking care to keep the edge at a different height with respect to the sealing bar.

1. The vacuum cycle is programmed as described in the USING THE PACKING MACHINE chapter.
2. Since liquids cannot be compressed, they do not need to be packed in a modified environment, that is, with the addition of inert gases.
3. All the packages can be stored in a cold room and stacked normally on top of one another.

### 4.6 - Packaging of products with the use of the inclined profiles provided

If the bag does not touch the bottom, it is possible to insert up to 2 shims (1) to raise the depth of the tank.

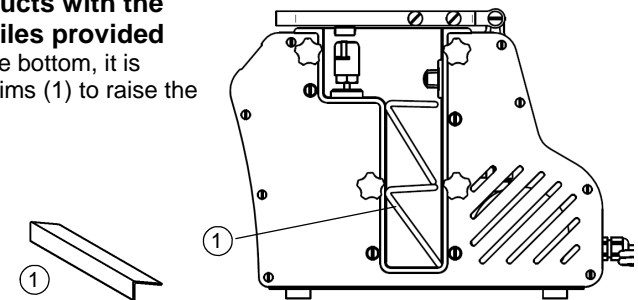

Fig. 4.6.1



### 4.3 - User menu



With the main switch set to ON (Fig. 4.1.1), press and hold for 3 seconds the ON/OFF button (Fig. 4.1.2) to enter the user menu. Use the arrow commands to view the list of machine functions that can be set and to modify the relevant values.



#### 4.3.1 - Oil heating and cleaning

O I L H E A T I N G C Y C L  
C l o s e b l a c k c a p

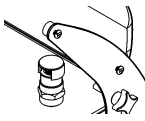

The message "Close black plug or chamber lid and press ON" will scroll on the second line of the display. Follow the instructions.

 The machine will start the oil heating process to reach the pre-set temperature of around 50°C. The cycle can be stopped by pressing the ON-OFF button. Touch the DOWN arrow  to skip to the next function.

#### 4.3.2 - Vacuum control



V a c u u m C t r l 1 0 0 %  
T I M E V A C U U M C T R L

The second screen of the display shows the message "VACUUM CONTROL" for setting the suction based on the percentage or the duration.



Press the UP  and DOWN  arrows to set the % or the duration with "TIME VACUUM CTRL". Confirm with the LH arrow. 

#### 4.3.3 - WiFi

W I F I  
O n l i n e

Press the LH arrow  to enter the Wi-Fi menu. The message e.g. **WIFI on line** will start flashing. Use the UP  and DOWN  arrows.





W I F I  
A P m o d e

**Wifi om line / Wifi AP mode / Deactivated** will appear in succession; if **Wifi AP mode** is chosen, to confirm and exit the edit mode, wait 5 seconds or press the LH arrow.  Touch the DOWN arrow  to skip to the next function.

#### 4.3.4 - Language

L A N G U A G E  
E n g l i s h

Press the LH arrow  to enter the menu dedicated to languages.

The word **italiano** will start flashing. Use the UP  and DOWN  arrows to scroll the languages in the system and select the desired language. To confirm and exit the edit mode, wait 5 seconds or press the LH arrow  until nothing more flashes. Touch the DOWN arrow  to skip to the next function.

### 1.8.1 - Warning and danger signs (Fig. 1.8.2)

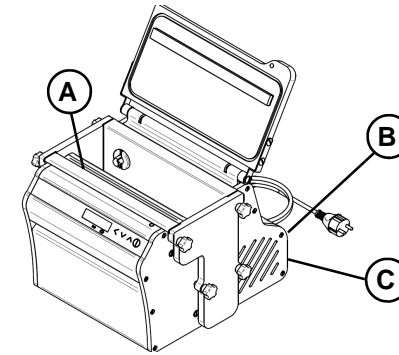
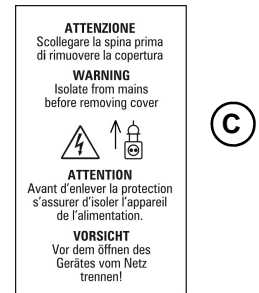

Fig. 1.8.2



## 2 - Technical specifications

### 2.1 - Main parts

To aid comprehension of the manual, the

1. Control panel
2. Vacuum chambre
3. Power cable
4. Main switch
5. Transparent cover
6. Silicone counter-bar
7. Seal
8. Vacuum suction duct
9. Sealing bar
10. Removable plexiglass side
11. Side fixing knob

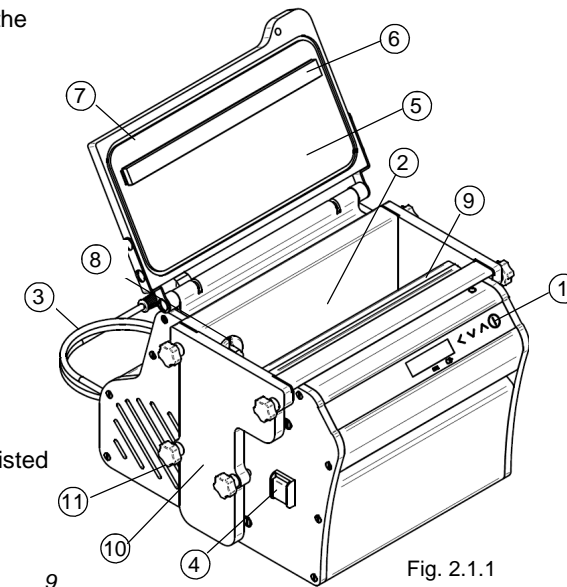

main components of the machine are listed below and shown in Fig. 2.1.1.

Fig. 2.1.1

## 2.2 - Caratteristiche tecniche

30	0,15	4 mc/h	310 mm	324x60x250 mm	120V/60Hz	0,125 L
----	------	--------	--------	---------------	-----------	---------

## 2.3 - Machine dimensions and weight

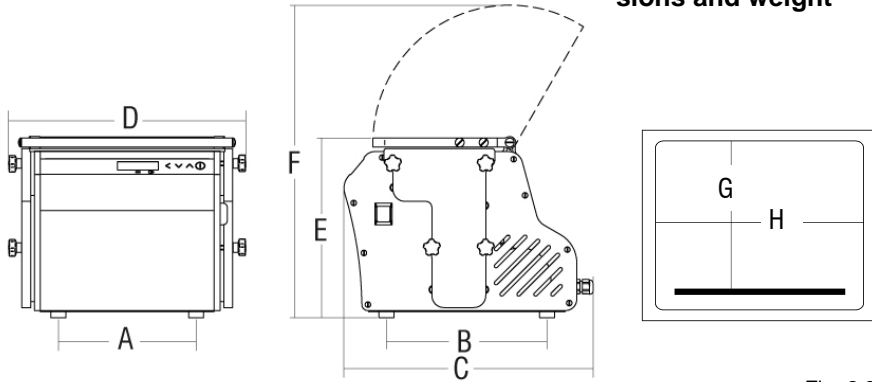

Fig. 2.3.1

	A	B	C	D	E	F	G	H	Net weight
	mm	mm	mm	mm	mm	mm	mm	mm	Kg
	230	268	416	398	300	520	86	324	22

## 4.2 - Programme menu

Switch on the machine by putting the main switch to ON (Fig. 4.1.1 - Ref. 1).

The display will switch on and show:

```
X X X X X X X X X
H W 2 . 0 F W 1 . 2
```

Lift the lid.

To access the programmes, press the button and use the UP and DOWN arrows to scroll the various programmes.

```
PROGRAM 1
4 . 0 s 4 0 s
```

There are 10 pre-set programmes from 0 to 9, which can be modified

```
MARINATION 8 M S
5 . 0 S 1 9 0 s
```

1 non-modifiable multi-step marination program, on a bag

To select a programme, press the LH arrow .

To modify a value, press the LH arrow again: the suction duration value will start flashing, use the UP and DOWN arrows to set the desired value and confirm with the LH arrow or wait 5 seconds.

```
PROGRAM 1
4 . 0 s 4 0 s
```

Subsequently, the sealing duration value will flash, then use the UP and DOWN arrows to set the desired value and confirm with the LH arrow or wait 5 seconds.

```
PROGRAM 1
4 . 0 s 4 0 s
```

After defining the programme to be used, close the cover and the machine will start working.

The following message will appear at the end of the process:

```
END
CYCLE
```

To interrupt a process under way, press the button:

Press it once to seal.

Press it twice to open the cover.

## 4 - Using the machine

### 4.1 - Control key

1. ON-OFF Main switch of the machine.  
Used to switch the machine on and off.  
It is located on the side of the machine.

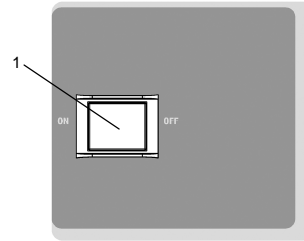

Fig. 4.1.1

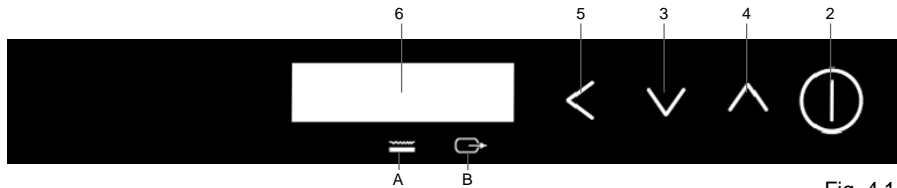

Fig. 4.1.2

### 2. START/STOP, functions:

If pressed once, after switching the machine on with the ON/OFF button (Ref. 1) and closing the cover, the machine will start with the last programme executed.

To access to programme menu.

To access to the user menu, press and hold for 3 seconds.

To exit the menus, press and hold for 3 seconds.

To start/stop the selected programme.

### 3-4. To scroll the software menu.

To select the memorised programmes.

To increase or decrease the selected values (where allowed):  
suction percentage, vacuum duration, sealing duration.

### 5. To access to the programme menus and confirm the selection.

### 6. Analogue display.

A = Sealing time.

B = Suction time.

**WARNING!** The changes are memorised automatically. After 5 seconds of inactivity from the change, the value stops flashing to confirm.

**We recommend switching the power switch or the line main switch off or pulling the plug out only for performing maintenance or specific operations described in the manual. The machine does not need to be switched off after every use since it automatically goes into stand-by and thus into energy saving mode without having to disconnect it. If the machine remains powered, all the control functions will be active and this guarantees improved efficiency and durability.**

## 2.4 - Wiring diagram

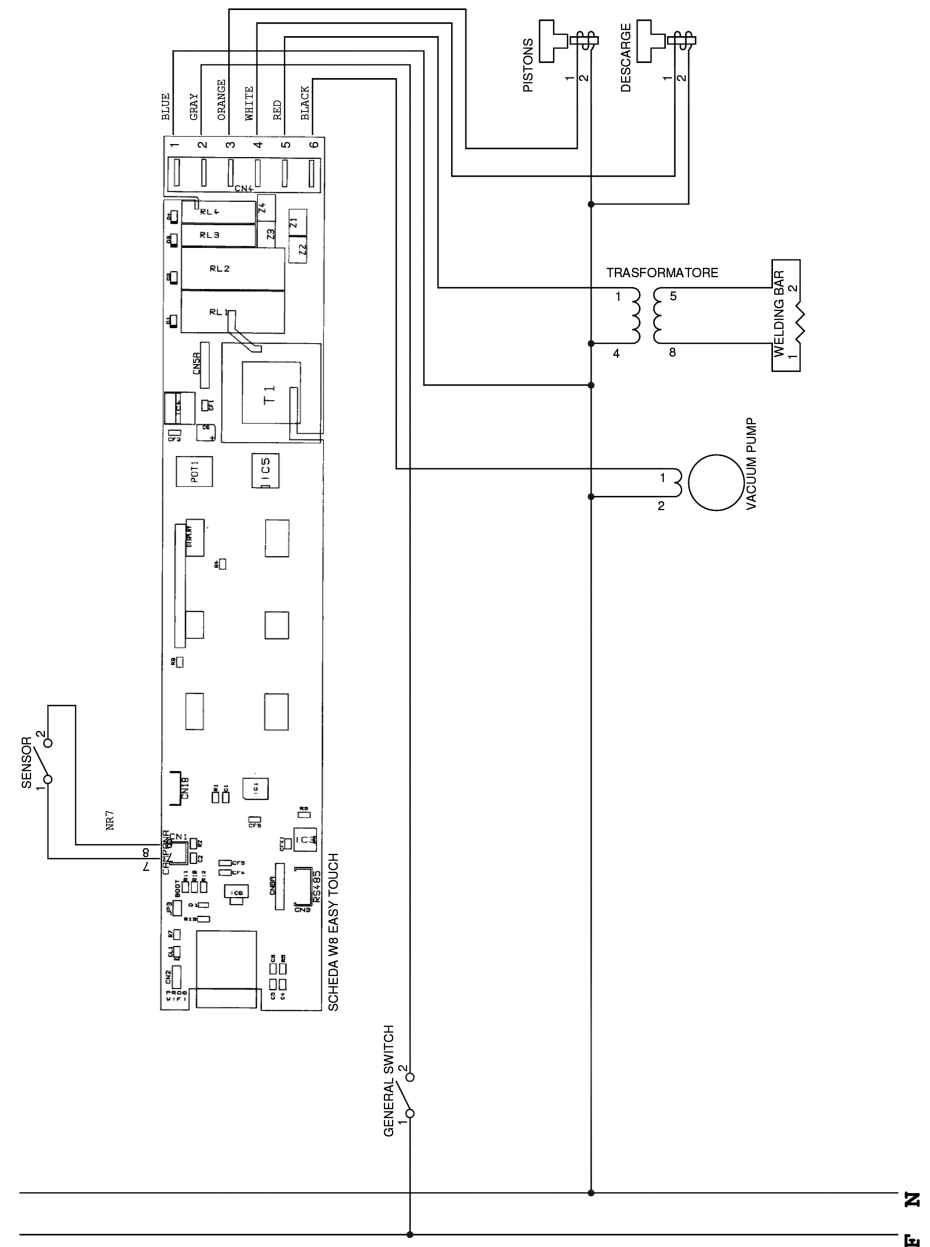

Fig. 2.4.1

### 3 - Factory testing, shipping, delivery and installation

#### 3.1 - Factory testing

The machine you have purchased was tested at our plants to verify its efficient operation and correct adjustment.

#### 3.2 - Delivery and handling

All shipped material is carefully checked prior to being handed over to the shipping agent.

Unless otherwise agreed with the Customer, and unless the shipping conditions demand special packaging, the machine is wrapped in nylon and cardboard. The dimensions of the package are shown in the table below.

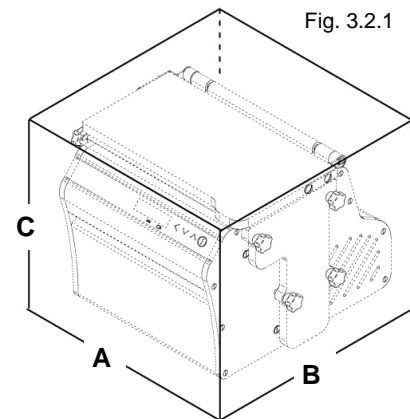

A	B	C	Gross weight
mm	mm	mm	Kg
515	435	385	24

When you receive the machine, check the condition of its packaging. If you notice any damage to the packaging, sign the delivery note with the following wording:

“Goods accepted with reservation...” and the

reason.

If you notice any damage to the components of the machine after opening the package, report it to the shipping agent within three days from the date shown on the documents.

#### 3.3 - Installation

After removing the packaging, verify that the packing machine is intact.

In particular, check that the machine is intact and without any visible damages that could have been caused by the transport.

In case of doubts, do not use the appliance and contact the manufacturer.

#### Installation site

Install the packing machine in a place with low humidity and far from heat sources.

**WARNING!** Prior to performing any check that implies the dismantling of certain parts, pull the plug out of the power outlet.

#### 3.3.1 - Disposing of packaging material

The packaging materials (cardboard, nylon, wood, etc.) can be regarded as solid urban waste. As a result, they can be disposed of freely.

Nylon is a polluting substance that releases toxic fumes when burnt.

Do not burn or dump it, but dispose of it according to the law.

If the machine is delivered to a country where special regulations apply, dispose of the

#### 3.4 - Connections

Before starting up the machine, check the oil level through the indicator on the pump.

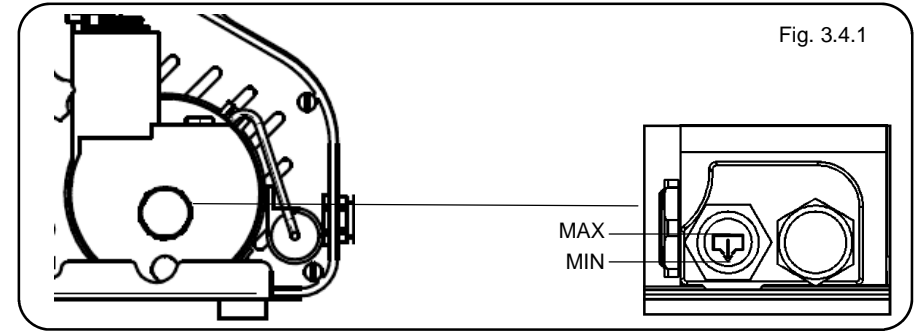

**Prior to connecting the packing machine, check that the rating plate data matches the power supply network data.**

The rating plate is located at the back of the machine.

After checking the level and closing everything, insert the plug back into the 230 V power outlet.

If the machine's plug is not compatible with the power outlet, contact professionally qualified personnel to replace the plug with a suitable one.

Said personnel must ascertain in particular that the cross-sectional size of the outlet's cables is suitable for the appliance's power input. In general, it is not advisable to use adapters, multiple sockets and/or extensions.

If these devices are indispensable, only use simple or multiple adapters and extensions conforming to the safety regulations in force, taking care not to exceed the current load limit and the maximum power limit marked on the multiple adapter.

#### 3.5 - Electrical connections

**WARNING!** Check that the power supply line has the same specifications as those shown on the machine's rating plate. All interventions must be carried out solely by specialised personnel expressly authorised by the relevant supervisor. Make the connection to a power line equipped with an efficient earthing socket.

#### 3.5.2 - 120 V / 60 Hz single-phase machine

In this configuration, the machine is supplied with a power cable with 3 x 1.5 mm gauge.

This cable is connected to a single-phase plug with three pins. Attach the cable to the 120 V-60 Hz single-phase power supply line by installing a 16 A residual current circuit breaker in between.



Consult the manufacturer for configurations differing from those mentioned above. If the power cable needs to be extended, use a cable of the same gauge as the original cable installed by the manufacturer.