

**REFRIGERATOR MANUFACTURER**  
**Turbo air**  
 more durable, efficient, beautiful

4184 E. Conant St.  
 Long Beach, CA 90808  
 Tel. 310-900-1000  
 Fax. 310-900-1077  
[www.turboairinc.com](http://www.turboairinc.com)

Project:	
Model #:	
Item #:	
Available W/H:	Qty:
Approval:	
AIA #:	SIS #:
CSI Section 11400	

## Vertical Air Curtain

Open Display Merchandisers

**Model : TOM-48EB-AN**

### Patented Self-Cleaning Condenser



This product is equipped with a fine mesh filter to the front of the condenser to catch dust, and a rotating brush that moves up and down daily to remove excess buildup outward and away.

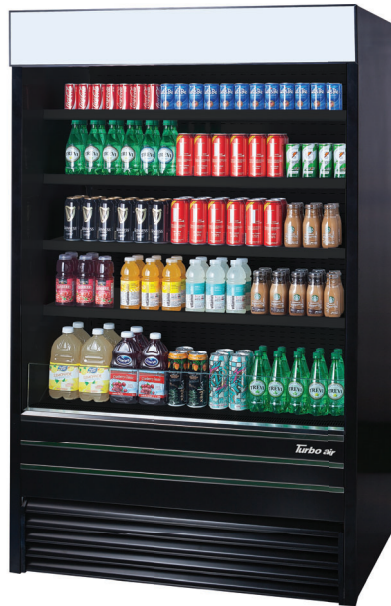

## ≡ FEATURES & BENEFITS ≡

### ▪ Self-Cleaning Condenser

The accumulation of dust in the condenser can cause the failure or breakdown of refrigerators. Refrigerators run normally until they reach a certain level of accumulation. At some point, when they are over the limit, their performance drops quickly resulting in damage to, or disposal of the stored products inside. The Self-Cleaning Condenser device keeps the condenser clean and prevents system failure by automatically brushing daily.

### ▪ Hydrocarbon refrigerants (R-290)

With innovative and eco-friendly technology, Turbo Air brings you hydrocarbon refrigerators designed to meet DOE's Energy Conservation Standards in 2017 and to use EPA's SNAP Program approved HC refrigerants. Hydrocarbon refrigerants do not deplete the ozone layer and have very low contribution to global warming (ODP-0, GWP-3).

### ▪ Modern design

By harmonizing curvature and rigidity, our modern style product designs are user-friendly while maintaining the highest product visibility and aesthetics. The glass front shield optimizes the merchandiser's display effects of fresh salads, sandwiches, desserts and beverages.

### ▪ LED interior lighting under each shelf

### ▪ Designed to enhance impulsive sales

Ideal for eye-catching displays and convenient access with fast service in high traffic area.

### ▪ Black coated galvanized steel interior

### ▪ Black coated galvanized steel solid shelves

### ▪ Energy saving night curtain standard

### ▪ Standard back-guard improves airflow

### ▪ Foamed with polyurethane, high-density cell insulation (CFC free)

### ▪ Perforated interior back wall and top for improved airflow

### ▪ Front air intake and rear air discharge



Model	CU./FT.	# of Shelves	HP	AMPS	Crated Weight (lbs.)	L x D* x H† (inches)
<b>TOM-48EB-A-N</b>	<b>22.6</b>	<b>4</b>	<b>3/4 x 2</b>	<b>15.5</b>	<b>743</b>	<b>48 x 29 1/2 x 80 1/2</b>

# Vertical Air Curtain

Open Display Merchandisers

## Model : TOM-48EB-A-N

ELECTRICAL DATA	
Voltage	115/60/1
Plug Type	 NEMA 5-20P
Full Load Amperes	15.5
Compressor HP	3/4 x 2
Cord Length (ft.)	97/8
Refrigerant	R-290
DIMENSIONAL DATA	
Net Capacity (cu. ft.)	22.6
Ext. Length Overall (in.)	48 (1220mm)
Ext. Depth Overall (in.)*	29 1/2 (749mm)
Ext. Height Overall (in.)†	80 1/2 (2046mm)
# of Shelves	4
Shelf Size (L x D) (in.)	44 3/4 x 15 1/2
Net Weight (lbs.)	573
Gross Weight (lbs.)	743

Design and specifications subject to change without notice.

Actual shipping weight may differ due to extra packing materials for product protection.

\* Depth does not include 1-1/4" for rear spacers.

† Height does not include 5/8" for bolt height.

- **WARRANTY :** 2 Year Parts and Labor Warranty  
Additional 3 Year Warranty on Compressor

### STANDARD FEATURES

- Simple plug-in installation
- Patented self-contained system, no plumbing required
- Solar powered digital thermometer
- Digital electronic thermostat with defrost control
- Price tag channel: P48E0010ZK (44 3/4"L)
- Bolt height adjustable up to 2 3/4"

### Recommended operating conditions

TOM models are designed to operate in an environment where temperature & humidity do not exceed 75°F and 55% respectively.

Units should not be installed near HVAC vents, fans or doorways that will disrupt the air curtain and compromise the function of the cabinet.

Air curtain models will run most efficiently when completely loaded with product.

When used as a built-in, required clearance for the rear is 4" and the top is 5".

### OPTIONAL ACCESSORIES

- 1.6" caster: CAS16WBT00 (non-brake)
- 4" caster, 1/2" diameter & 13 TPI: 30265L0400 (non-brake), 30265L0300 (w/ brake)
- 6" leveling seismic leg (1/2", 13 TPI): 30221M0700
- Security cover: SC-48-EB (Black), SCM-48-E (White), SCM-48-EB (Black), SCS-48-E

## PLAN VIEW

(unit : inch)

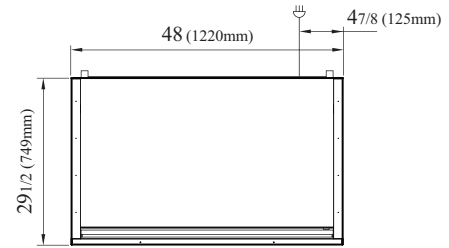

TOP VIEW

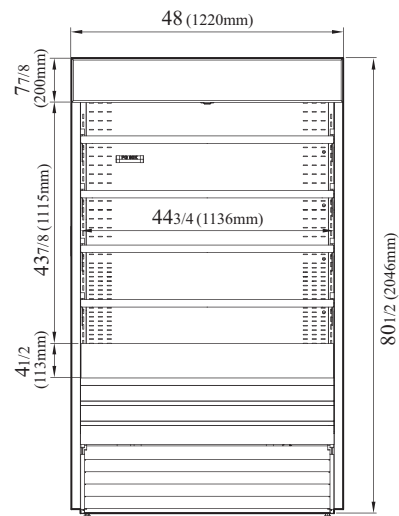

FRONT VIEW

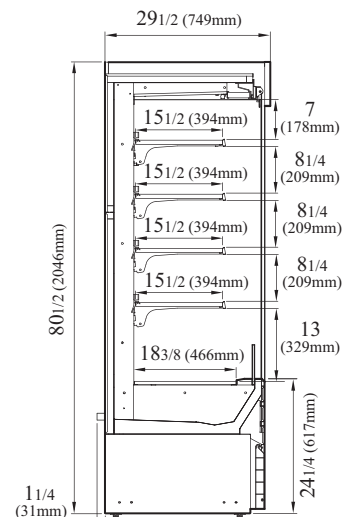

SIDE VIEW

Ver.20241212



- Turbo Air: 800-627-0032
- Radiance: 800-500-3519
- Warranty: 800-381-7770
- AC: 888-900-1002