

## Type: Round Stone Hearth Oven

### Model: RND1300

The Beech RND1300 Stone Hearth Oven is manufactured from a high grade castable ceramic material and completely enclosed in a housing of 5mm (1/4") mild steel. This mild steel outer casing and associated lifting hooks make installation easy which reduces potential damage to the oven. The inside diameter of the oven is 1300mm (51.2") and it has a 1.33m<sup>2</sup> (14.3ft<sup>2</sup>) cooking surface. This style of oven can be fired using wood, gas back-up or full gas.

The spectacular performance of a Beech Oven is a result of the huge thermal mass of the unique ceramic cast interior. Beech Ovens have **TWICE** the mass (*thermal mass*) of any other pre-cast oven on the market. The unique oven design results in superior cooking performance and exceptional thermal efficiency.

The cooking surface of the oven (*stone hearth*) is constructed using high quality 75mm (3") thick Fire bricks, renowned for their excellent cooking attributes and incredible wear resistance. The use of bricks eliminates the unsightly cracking associated with one piece floors. The bricks sit upon a 25mm (1") VF insulating board and a further 5mm (1/4") reinforced mild steel base.

The unique three (3) piece oven design allows all Beech Ovens to be installed through a standard 700mm (27.5") doorway. All Beech Ovens can be installed without the use of a crane therefore significantly reducing the costs of installation. The oven body comes with an exclusive 4 year guarantee.

The oven can be installed within 75mm (3") (*including 50mm (2") of insulating wool and 25mm (1") air gap*) of non-combustible material (*check local building and fire codes*). The oven exhausts through a spigot above the oven mouth. The oven must be vented in accordance with local and/or national codes. Refer to "Duct Design Options" or for more information, refer to the Installation and Operation Manual located on our website [www.beechovens.com](http://www.beechovens.com)  
Allow 600mm sq (24" sq) ventilation into the underside of the oven for secondary air to the gas burner (*if applicable*).

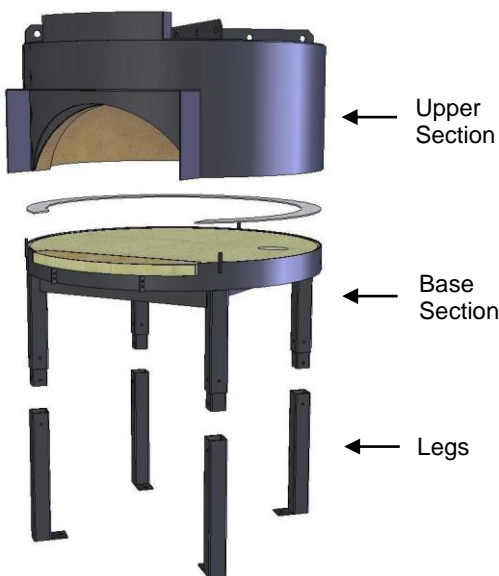

### Unique Features

- Wood and/or thermostatically controlled gas system.
- Easy installation into most areas (*three (3) piece assembly*).
- Stainless steel plug door for oven mouth.
- Any gas type – Specify at order time.

### Optional Accessories

- Internal spotlight.
- Gas powered Char Grill with slide out drawer.
- Viewing window available in any location.
- Various shape/design facades and Stainless Steel Hearths.
- Thermostatically controlled Display burner.
- Exhaust Fan/Hood.
- Stainless Steel pizza tools.
- Service panels/hearth/intel extensions.

### Approximate Pizza Capacity Per Hour

At 250°C (482°F) floor temperature the oven will cook:

Size	200mm (8")	250mm (10")	300mm (12")	400mm (16")
Pizza / hour	140	110	85	55

**NOTES:**  
 CONNECTION TO APPROVED FLUE/DUCTING REQUIRED  
 (CHECK LOCAL CODES AND REGULATIONS)

SERVICES REQUIRED - SEE BLUE TEXT

THE OVEN IS DELIVERED IN THREE (3) SECTIONS:  
 UPPER SECTION - Approx 1050kg (2310lb)  
 BASE SECTION - Approx 495kg (1089lb)  
 LEGS - Approx 10kg (22lb) EACH

TOTAL WEIGHT = Approx 1650kg (3630lb)

FOR INSTALLATION INSTRUCTIONS SEE INSTALLATION  
 AND OPERATION MANUAL



STAINLESS STEEL  
 DOOR PLUG  
 REMOVED FOR CLARITY

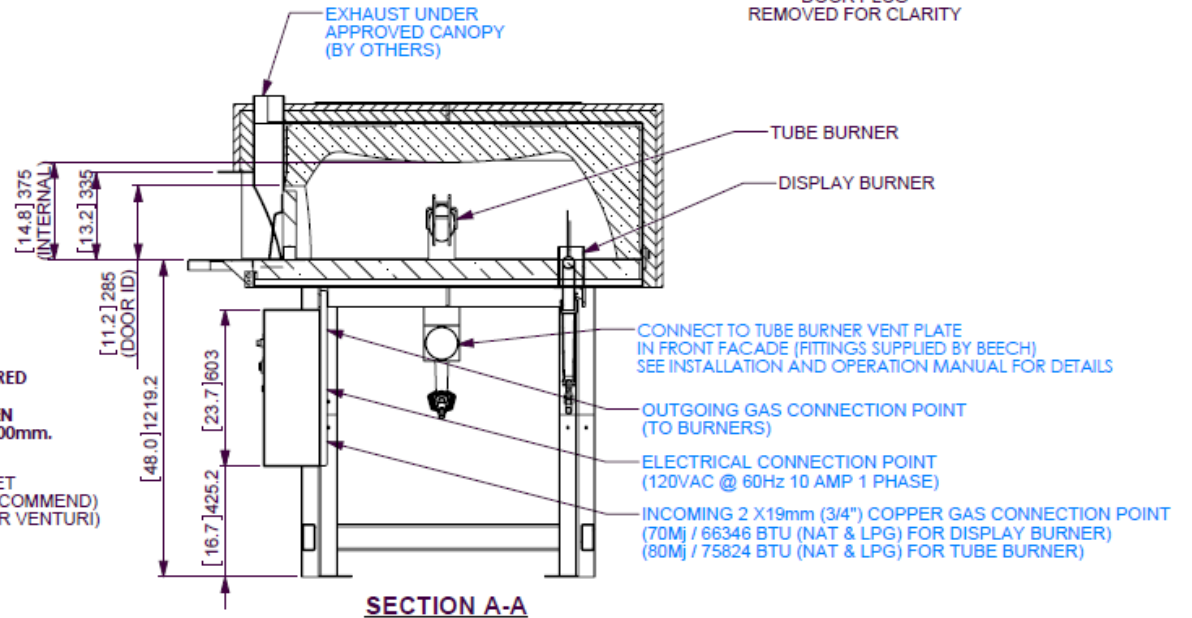
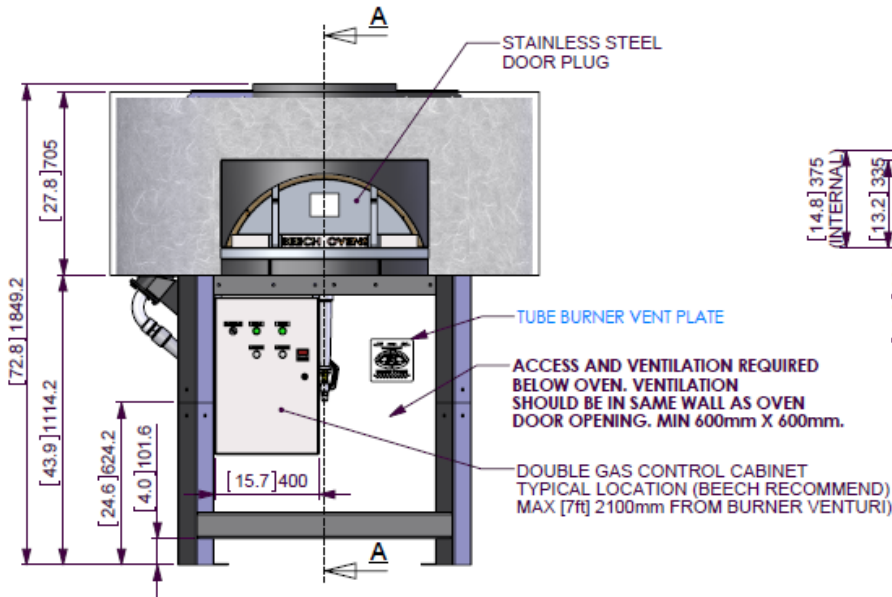
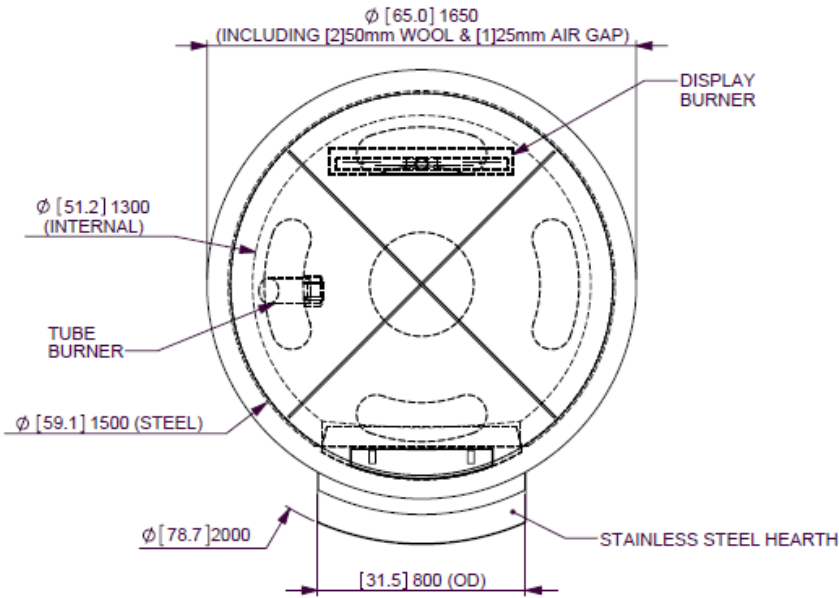

0	ISSUED FOR CONSTRUCTION		
REV.	DESCRIPTION OF CHANGES	DATE	CHANGED BY

LAST EDITED: Friday, 4 September 2015 8:46:44 AM

©Copyright 2015 Beech Ovens Pty Ltd. All rights reserved.



www.beechovens.com

Drawn	M. WEBB	Checked	Scale	1:20	Date	4/09/2015
ROUND OVEN Ø1300mm INTERNAL FGL (DISPLAY + TUBE BURNER LEFT) SS HEARTH						A3 NTS - SITE MEASURE

RND1300-2020 - DETAILS-USA

Folder: \\wb-sbsvr\GroupData\Beech Ovens\Engineering\Drawings\Standard Ovens & Components\RND1300\2000