

Refrigeration Equipment 1-Door Full Height Reach In Back Room Freezer 31" Long

ITEM # _____

MODEL # _____

NAME # _____

SIS # _____

AIA # _____



738279 (KCHRI25R1DFE)

1-Door Full Height Reach In
Back Room Freezer 31" Long

Short Form Specification

Item No. _____

1 full door freezer with door in 430 stainless steel, exterior back and bottom panels in galvanized steel, exterior side and top panels in prepainted steel; interior back, side, top and bottom panels in white High Impact Polystyrene. Control with cabinet temperature display. Self-closing and on-site reversible door feature with lock and key. Temperature range: - 8 °F min / 5 °F max.

R290 gas in the refrigeration circuit.

ETL Safety and Sanitation certifications.

3/5 Years warranty.

Main Features

- External temperature display.
- Removable gasket for easy cleaning operations.
- Fin & Tube Condenser improves performance in high temperature environments.
- Automatic Defrost Cooling System provides worry-free performance.
- Electronic Temperature Control, quick and simple to set, with control display for easy monitoring.
- Cabinet completely insulated with high density polyurethane for low environmental impact.
- Back bottom mounted cooling unit guarantee an easy access and cleaning.

Construction

- Lockable door.
- Self-closing door with 90-degree stay-open feature.
- Heavy duty casters.
- Pre-wired heavy duty power cord.
- Heavy duty door hinges.
- Magnetic gasket removable without tools for easy cleaning.
- PVC shelves.

Sustainability

- CFC and HCFC free, highly ecological refrigerant type: R290 (ecological gas in foam: cyclopentane). Hydrocarbon refrigerant gas R290 for the lowest environmental impact (GWP=3), to reduce green house and ozone depletion effects.
- Hydrocarbon refrigerant gas R290 for the lowest environmental impact (GWP=3) - CFC and HCFC free.
- High efficiency components to minimize the energy consumption still guaranteeing the highest performances.

Included Accessories

- 3 of Shelf for 25" Reach-In PNC 880678

Optional Accessories

- Shelf clips (4-pack) PNC 880611
- Shelf for 25" Reach-In PNC 880678

APPROVAL: _____

Front

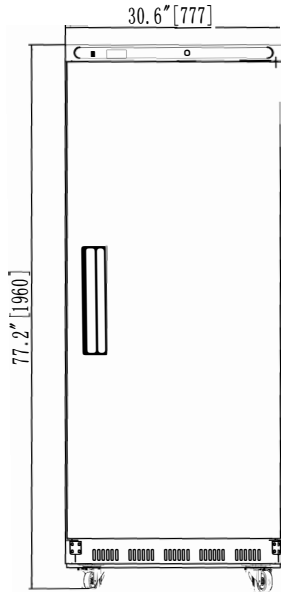

Side

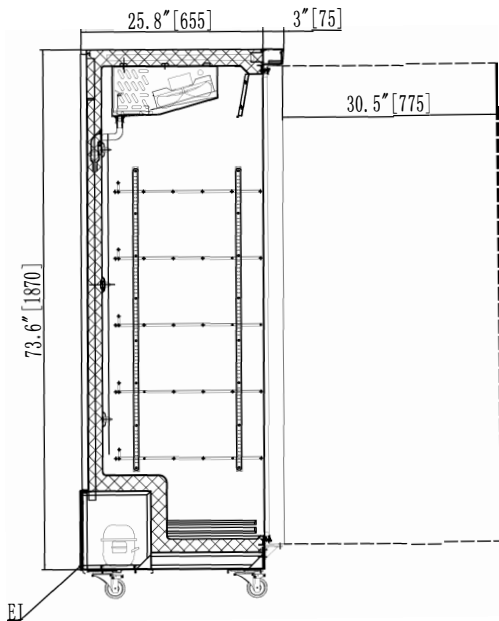

EI = Electrical connection

Top

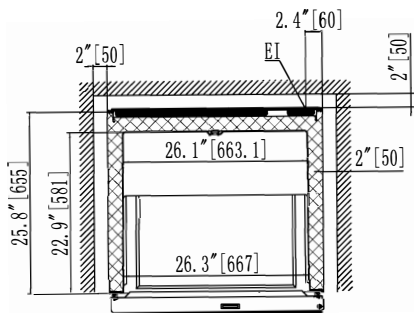

Electric

Supply voltage:

738279 (KCHRI25R1DFE) 115 V/1 ph/60 Hz

Electrical power, max:

0.407 kW

Plug type:

USA NEMA 5-15P

Capacity:

Gross capacity: 22.7 cu.feet

Key Information:

Door hinges:

Right Side

External dimensions, Width:

30 9/16" (777 mm)

External dimensions, Depth:

28 3/4" (730 mm)

External dimensions, Height:

77 3/16" (1960 mm)

Number and type of doors:

1 Full

Internal Dimensions (depth):

22 3/4" / (578 mm)

Internal Dimensions (height):

65 3/8" / (1660 mm)

Internal Dimensions (width):

26 3/8" / (670 mm)

Shipping height:

82 11/16" (2100 mm)

Shipping weight:

284 lbs (129 kg)

Shipping volume:

47.34 ft³ (1.34 m³)

Number and type of grids (included):

3 - Vinyl-Coated steel

Type of external material:

Prepainted Steel

Type of internal material:

High Impact White Polystyrene

Warranty:

3 / 5 years

Approvals

ETL C&US;ETL SANITATION

Refrigeration Data

Compressor power:

3/4 hp

Operating temperature min.:

-10.01 °F

Operating temperature max.:

0 °F

Condenser type:

Fin & tube

Defrost type:

auto defrost

Sustainability

Current consumption:

8 Amps

Refrigerant type:

R290

GWP Index:

3

Refrigerant weight:

119 g