



Profit from the Eagle Advantage®

Specification Sheet

Short Form Specifications

Eagle Extended Undercounter Heated Cabinet, model _____ . Aluminum interior and exterior, patented TEMP-GARD® air flow design, (insulated/non-insulated), bottom mount control panel, door (solid, or with polycarbonate window), and adjustable digital temperature control system with LCD readout. Removable (wire/universal wire) slides on 2¼" standard spacing, full perimeter bumper, 8' cord & plug, and 3"-diameter heavy duty polymer swivel casters, two with brakes.



extended undercounter heated cabinet with clear polycarbonate door

Options / Accessories**

- Pass-through doors
- Alternate slide spacing (_____)
- Alternate voltage

**See spec sheet #EG60.28 for options and accessories.

EAGLE GROUP
100 Industrial Boulevard, Clayton, DE 19938-8903 USA
Phone: 302-653-3000 • Fax: 302-653-2065
www.eaglegrp.com

Foodservice Division: Phone 800-441-8440
MHC/Retail Display Divisions: Phone 800-637-5100

For custom configuration or fabrication needs, contact our **SpecFAB® Division**.
Phone: 302-653-3000 • Fax: 302-653-3091 • e-mail: specfab@eaglegrp.com

Item No.:	_____
Project No.:	_____
S.I.S. No.:	_____

Panco® Transport Heated Cabinets—Undercounter

QUICK-ORDER #S:

- | | |
|---------------------------------|---------------------------------|
| <input type="checkbox"/> EUHC-A | <input type="checkbox"/> EUHC-E |
| <input type="checkbox"/> EUHC-B | <input type="checkbox"/> EUHC-F |
| <input type="checkbox"/> EUHC-C | <input type="checkbox"/> EUHC-G |
| <input type="checkbox"/> EUHC-D | <input type="checkbox"/> EUHC-H |



Design and Construction Features

- For use in operations where hot food is to be stored or transported and held at hot food serving temperatures.
- Patented TEMP-GARD® air flow design (patent #6,847,013 B2).
- 30½" (775mm) overall height.
- 32½" (826mm) "extended" width*.
- Standard units feature 120-volt 20-amp electricity**.
- Aluminum construction on exterior and interior.
- Bottom mounted control panel and heating system removes easily for cleaning or servicing.
- 2000-Watt heating capacity via two 1000-watt elements for heated air, with internal air temperature up to 200°F. 1500-Watt is optional on 120V only.
- High-temperature protection device with caution alarm and auto reset.
- Full 270° open door swing via ⅝" (5mm)-thick heavy duty aluminum hinges with stainless steel pin.
- Positive closing magnetic door latch.
- Removable slides with 3" (76mm) standard slide spacing.
- Available in both non-insulated and insulated.
- Insulated units feature identifying color stripe on both sides.
- 8' (2438mm) cord and plug provided.
- Full perimeter bumper on all models.
- Heavy duty 3" (76mm) polymer swivel casters, two with brake.

* Undercounter units are available in "extended" width only.

Digital Control System on all units

- Easy-touch front control panel with membrane switches.
- Liquid Crystal Display (LCD) read-out.
- Digital setting of air temperature.
- Overheat caution alarm.
- Embedded LED technology.
- Upgrade software control.

Certifications / Approvals
 
New York M.E.A. 245-02-E

AUTOQUOTES



EG60.25C Rev. 09/12

Spec sheets available for viewing, printing or downloading from our online literature library at www.eaglegrp.com

Eagle Foodservice Equipment, Eagle MHC, SpecFAB®, and Retail Display are divisions of Eagle Group. ©2012 by the Eagle Group



Item No.: _____
 Project No.: _____
 S.I.S. No.: _____

Panco® Transport Heated Cabinets—Extended Undercounter

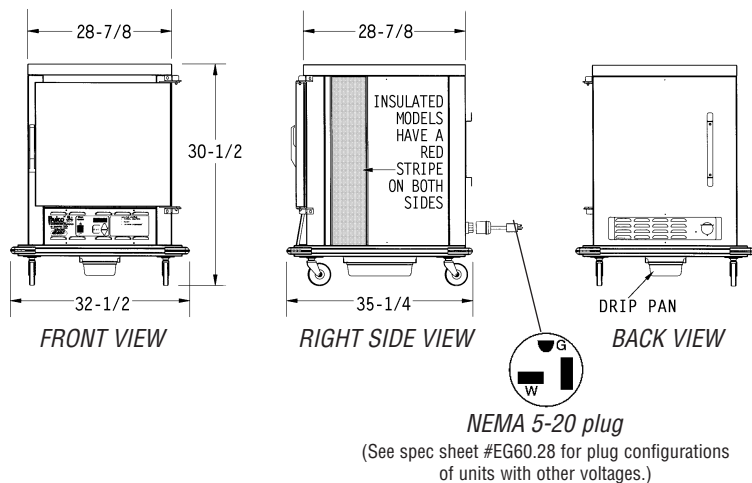

Maximum Pan Capacities of Extended Undercounter Units

Based on standard slide spacings of 3" (76mm).
 For information about standard number of slides that come with units, see chart below.
 For information about replacement slides available, see spec sheet #EG60.28.

Cabinet Width	Slide Type	18" x 26" sheet pans	13" x 18" sheet pans	12" x 20" food pans
Extended	Wire	n/a	n/a	10
Extended	Wire Univ ¹	5	10	10



Units with Wire Slides – Comes with 5 pairs of slides.
 Max pan capacities: (10) 12" x 20" x 2 1/2" food pans.

Non-Insulated Units		Insulated Units		door style (single door)	width x depth x height in. mm		weight lbs. kg	
model #	quick-order #	model #	quick-order #		in.	mm	lbs.	kg
HCUSSN-RA3.00-120	EUHC-A	HCUESSI-RA3.00-120	EUHC-C	solid	32 1/2" x 35 1/4" x 30 1/2"	826 x 895 x 775	155	70.3
HCUELSN-RA3.00-120	EUHC-B	HCUELSI-RA3.00-120	EUHC-D	with poly window	32 1/2" x 35 1/4" x 30 1/2"	826 x 895 x 775	171	77.6

Units with Wire Universal Slides – Comes with 5 pairs of slides.
 Max pan capacities: (5) 18" x 26" sheet pans, (10) 13" x 18" sheet pans, or (10) 12" x 20" x 2 1/2" food pans.

Non-Insulated Units		Insulated Units		door style (single door)	width x depth x height in. mm		weight lbs. kg	
model #	quick-order #	model #	quick-order #		in.	mm	lbs.	kg
HCUSSN-RC3.00-120	EUHC-E	HCUESSI-RC3.00-120	EUHC-G	solid	32 1/2" x 35 1/4" x 30 1/2"	826 x 895 x 775	155	70.3
HCUELSN-RC3.00-120	EUHC-F	HCUELSI-RC3.00-120	EUHC-H	with poly window	32 1/2" x 35 1/4" x 30 1/2"	826 x 895 x 775	171	77.6

(Note: Dimensions of slides shown above are for slides that fit onto units with "narrow" width, which are listed in the charts above. For units with optional "extended" and "wide" widths, dimensions of slides vary.)

EAGLE GROUP
 100 Industrial Boulevard, Clayton, DE 19938-8903 USA
 Phone: 302-653-3000 • Fax: 302-653-2065
 www.eaglegrp.com

Foodservice Division: Phone 800-441-8440
 MHC/Retail Display Divisions: Phone 800-637-5100

Printed in U.S.A.
 ©2012 by Eagle Group
 Rev. 09/12

Spec sheets available for viewing, printing or downloading from our online literature library at www.eaglegrp.com

Although every attempt has been made to ensure the accuracy of the information provided, we cannot be held responsible for typographical or printing errors. Information and specifications are subject to change without notice. Please confirm at time of order.