



BEVERAGE-AIR®

Project: _____	AIA#
Item: _____	
Location: _____	SIS#
Approved: _____	

UCF24AHC UNDERCOUNTER FREEZER

UNDERCOUNTER FREEZER

UCF24AHC Solid Door Freezer

Hydrocarbon Series

**MODEL:
UCF24AHC**

7 Year Parts/Labor Warranty
7 Year Compressor Warranty

CABINET CONSTRUCTION

- Stainless steel front, sides, top, door and grille (galvanized steel back & bottom)
- Interior liner is made of corrosion resistant aluminum
- Full electronic control
- Undercounter feature a 1/2" thick sub-top
- Interior thermometer is standard
- Self-closing door with 120° stay-open feature, on cartridge style hinges
- Door opening includes low wattage, anti-condensate heater
- Magnetic gasket attached to each door for positive seal
- 6" Casters, two (2) with brakes standard
- Two epoxy-coated steel wire shelves
- Field-reversible door (hinge kit not included)

OPTIONS & ACCESSORIES

- Stainless steel back
- Stainless steel interior
- Right or left hinged door
- Additional shelves
- Shelf clips
- Glass door option
- Lock
- Wire shelf divider
- 3" Casters
- 6" Legs (stainless steel, black or seismic/flange)
- Low profile casters
- Roller kit
- Remote option* (see note on back on page)

REFRIGERATION SYSTEM

- Uses environmentally friendly, energy efficient R290 refrigerant, and meets all regulatory requirements for CARB, SNAP, DOE & more
- Adaptive defrost
- Epoxy coated evaporator coil
- Freezers capable of maintaining product temperature of -10°F



Please verify qualifying units by visiting:
www.energystar.gov/cfs

3779 Champion Blvd., Winston-Salem, NC 27105
1-888-845-9800 Fax: 1-336-245-6453
Beverage-Air.com Sales@bevair.com



BEVERAGE-AIR

MODEL	UCF24AHC
EXTERNAL DIMENSIONAL DATA	
Width Overall	24"
Depth Overall with Handle & Bumper	32"
Height Overall with 6" Casters	34 5/8"
Number of Doors	1
Depth with Door Open 90°	52 1/4"
Door Opening	19 5/8" x 21 5/8"
INTERNAL DIMENSIONAL DATA	
NET Capacity (cubic ft.)	4.9
Internal Width Overall (in)	20"
Internal Depth Overall (in)	15 3/8"
Internal Height Overall (in)	23"
Number of Shelves	2
ELECTRICAL DATA	
Full Load Amperes	2.5
REFRIGERATION DATA	
Horsepower	1/4
Capacity (BTU/Hr)	857
Heat Rejection (BTU/Hr)	1285.5
Charge (lbs/grams/ounces)	0.0992 / 45 / 1.59
SHIPPING DATA	
Gross Weight - Crated	182 lbs
Height - Crated	38"
Width - Crated	29"
Depth - Crated	32"

*NOTE: Remote units are field wired and come with 6" legs. Refrigerant must be specified at time of order.

We reserve the right to change specifications and product design without notice. Such revisions do not entitle the buyer to corresponding changes, improvements, additions or replacements for previously purchased equipment. Dimensional tolerances +/- 1/4". Metric dimensions (MM).

Undercounter Freezer Model: UCF24AHC

Model Views

Required Clearance: 3" Bottom & 2" Rear

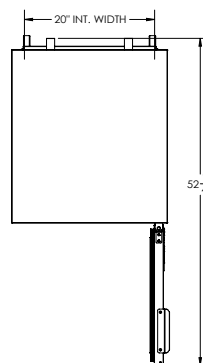

PLAN VIEW

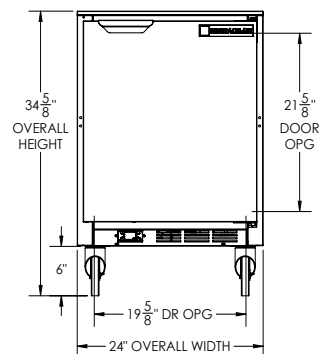

ELEVATION VIEW

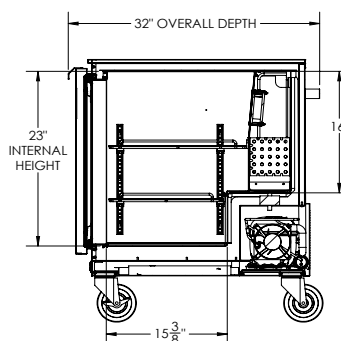

SIDE VIEW

ELECTRICAL CONNECTION



115/60/1
NEMA 5-15P

Unit pre-wired at factory and include 8' long cord and plug set.

