

Type: Duck Oven

Model: DCK0850

The Beech DCK0850 Duck Oven is manufactured from a high grade castable ceramic material and completely enclosed in a housing of 5mm (1/4") mild steel. This mild steel outer casing and incorporated lifting hooks make installation easy which reduces potential damage to the oven. The inside measurements of the oven are 850mm (33.5") x 955mm (37.5") and it has a 0.80m² (8.6ft²) floor area. This style of oven can be fired using wood, gas back-up or full gas.

The spectacular performance of a Beech Oven is a result of the huge thermal mass of the unique ceramic cast interior. Beech Ovens have **TWICE** the mass (*thermal mass*) of any other pre-cast oven on the market.

The floor surface of the oven (*stone hearth*) is constructed using high quality 75mm (3") thick Fire bricks, renowned for their excellent cooking attributes and incredible wear resistance. The use of bricks eliminates the unsightly cracking associated with one piece floors. The bricks sit upon a 25mm (1") VF insulating board and a further 5mm (1/4") reinforced mild steel base.

The unique three (3) piece oven design allows all Beech Duck Ovens to be installed through an 1100mm (43") doorway. All Beech Ovens can be installed without the use of a crane therefore significantly reducing the costs of installation. The oven body comes with an exclusive 4 year guarantee.

The oven can be installed within 75mm (3") (*including 50mm (2") of insulating wool and 25mm (1") air gap*) of non-combustible material (*check local building and fire codes*). The oven exhausts through a spigot above the oven mouth. The oven must be vented in accordance with local and/or national codes. Refer to "Duct Design Options" or for more information, refer to the Installation and Operation Manual located on our website www.beechovens.com
Allow a 600mm x 600mm (24" x 24") ventilation access panel into the underside of the oven for secondary air to the gas burner (*if applicable*).

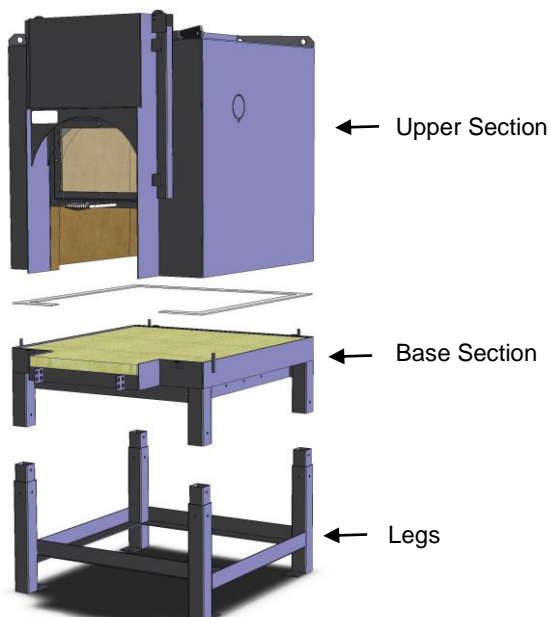

Unique Features

- Wood and/or thermostatically controlled gas system.
- Easy installation into most areas (*three (3) piece assembly*).
- Sliding glass door for easy access to hanging rails.
- Any gas type – Specify at order time.
- Internal spotlight.
- SS Drip Tray, Fire Tray and Cast Iron Fire Grate.
- Tool Kit including hanging hooks and duck retriever.

Optional Accessories

- Viewing window available in any location.
- Stainless Steel Hearth.
- Thermostatically controlled Aeromatic burner.
- Exhaust fan/Hood.
- Service panels, hearths, lintels extensions.

Approximate Duck Capacity

The DCK0850 will accommodate approximately 8 ducks at any one time. Approximate cooking time for full capacity is 50 minutes.

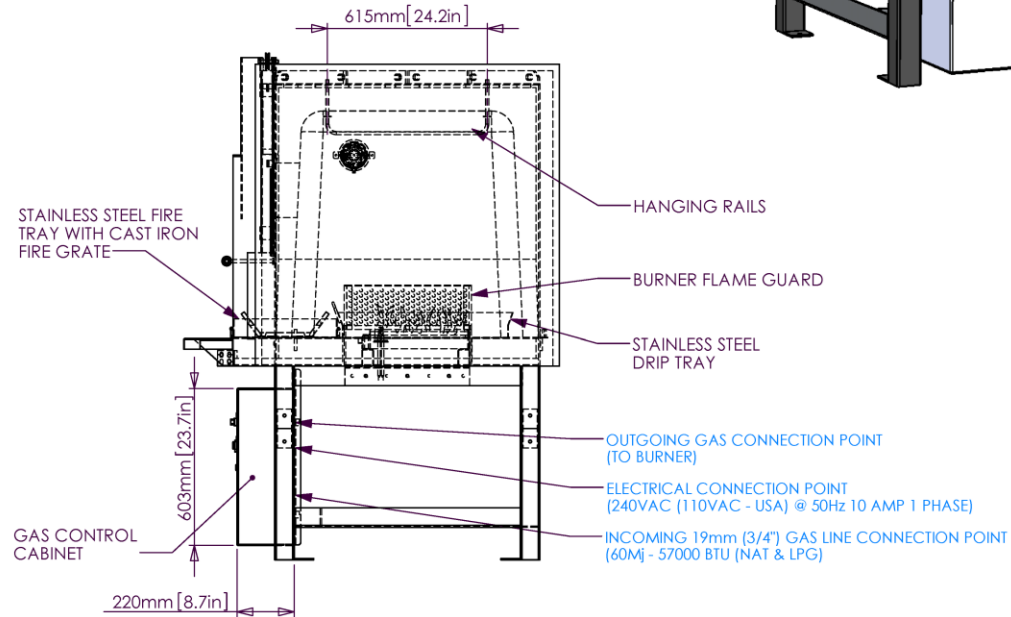
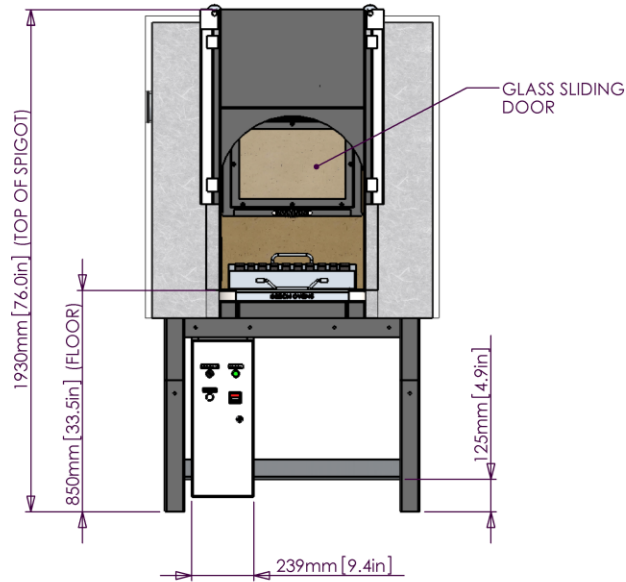
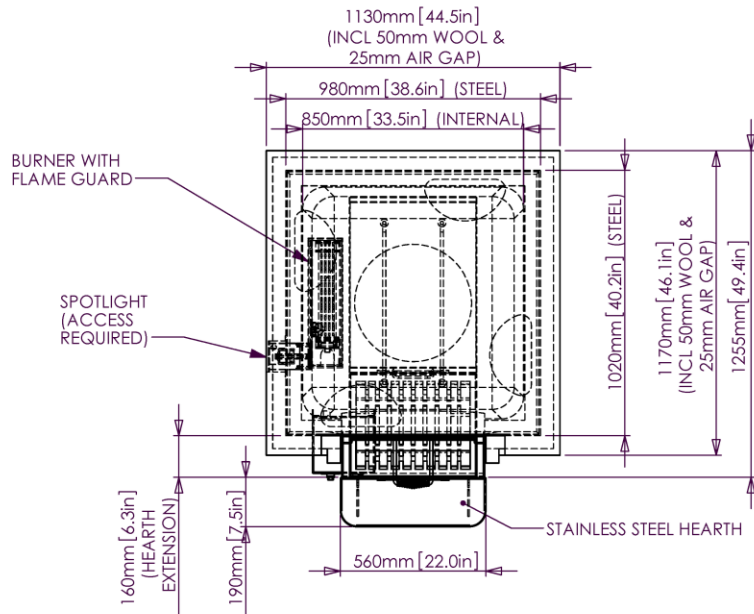

NOTES:
 CONNECTION TO APPROVED FLUE/DUCTING REQUIRED
 BEECH OVENS RECOMMEND INSTALLATION UNDER AN APPROVED EXHAUST CANOPY.
 (CHECK LOCAL CODES AND REGULATIONS)

SERVICES REQUIRED - [SEE BLUE TEXT](#)

THE OVEN IS DELIVERED IN THREE (3) SECTIONS:
 UPPER SECTION - Approx 610kg (1342lbs)
 BASE SECTION - Approx 320kg (704lbs)
 LEGS - Approx 60kg (132lbs)

TOTAL WEIGHT = Approx 1100kg (2420lbs)

FOR INSTALLATION INSTRUCTIONS SEE INSTALLATION AND OPERATION MANUAL.

SPOTLIGHT (ACCESS REQUIRED)

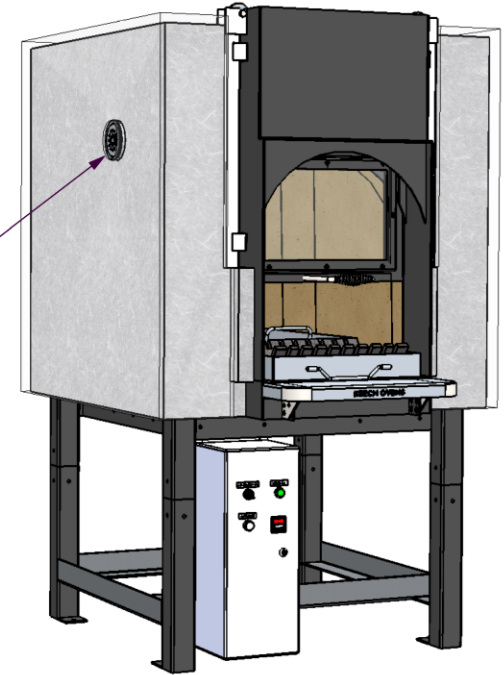

REV.	DESCRIPTION OF CHANGES	DATE	CHANGED BY
0	ISSUED FOR CONSTRUCTION		

LAST EDITED: Tuesday, 17 January 2012 8:16:29 PM

©Copyright 2006 Beech Ovens Pty Ltd. All rights reserved.



Drawn S Trood	Checked	Scale 1:20	Date 17/01/2012
DUCK OVEN 850mm (33.5") WIDE INT GBL - GAS BACK-UP LEFT SS HEARTH_SPOT(L)			A3 NTS - SITE MEASURE

DCK0850-2010 - DETAILS