

1 Trolley Roll-In Blast Chiller/Shock Freezer

- Exceeds food safety standards chilling from 194°F to 37°F in 90 min & freezing from 94°F to 0°F in 270 min
- Technology proven to preserve nutrients, aid in reducing food waste, and minimize preparation times
- Roll-in unit fits 1 full-sized speed rack or combi cart (not included)
- Touch screen control allows for preset chill and freeze cycles and custom recipe creation



UCBF559-SS12A

(Cabinet)



(Remote condenser unit included)

Model	Description	Voltage/Hz/Phase/Amps	Shipping Weight
UCBF559-SS12A	1 Trolley Roll-In Blast Chiller/Shock Freezer, (Cabinet)	230 / 60 / 1 / 4	1,565 lbs
	Remote Condenser	230 / 60 / 3 / 15	

Specifications

UCBF559-SS12A cabinet dimensions: 88 7/8" H x 59 1/16" W x 52 11/16" D

UCBF559-SS12A remote condenser unit dimensions: 28" H x 56 1/8" W x 40 1/2" D

AISI 304 Stainless steel interior and exterior, ETL sanitation certified

Autodefrost

Blast chilling yield (194°F to 37°F in 90 min): 440.93 lb / Shock freezing yield (194°F to 0°F in 270 min): 385.81 lb

Environmentally friendly R452A refrigerant: 212 oz (6.0 kg)

Interior rounded corners, removable door gasket, and evaporator compartment for easy cleaning

Multi-core probe with 4 reading points

NSF/ANSI Standard 7 compliant

Operating temperature range: -40°F to 50°F

Remote condensing unit included (assembly required). 33' run distance

Self-closing door with 105° stop. Lock included.

Self-lubricating, sealed cast iron evaporator fan motor with high volume air flow design

5 1/2" ramp included

7" digital touch screen control with HACCP data tracker and alarms. Cycles include soft chill, hard chill, soft freeze, hard freeze, holding, and end of cycle hold mode.



Product Specifications • 1 Trolley Roll-In Blast Chiller/ Shock Freezer

Top

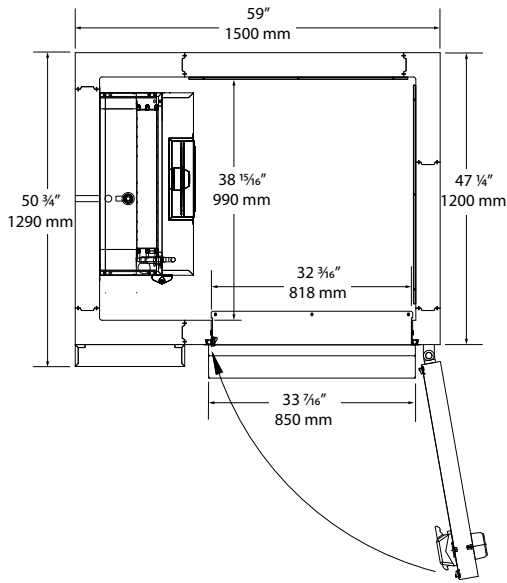

Remote Condensing Unit

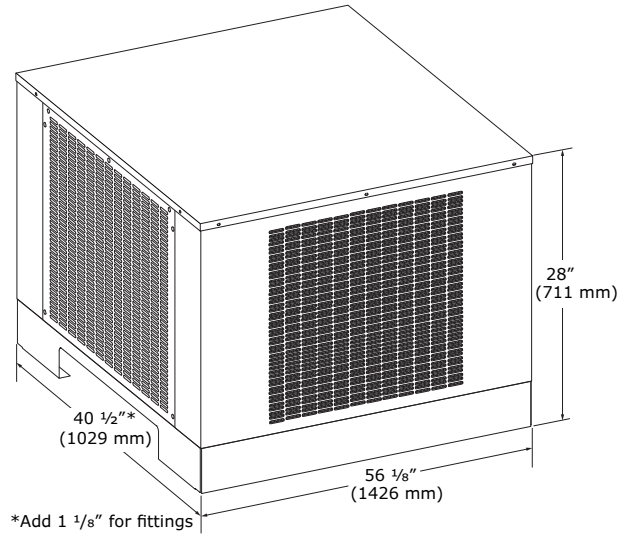

Front

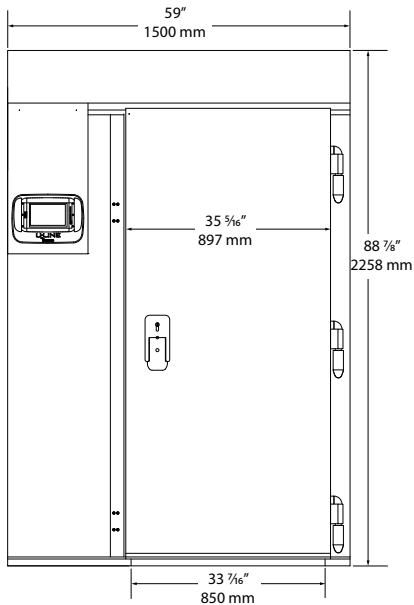

Side

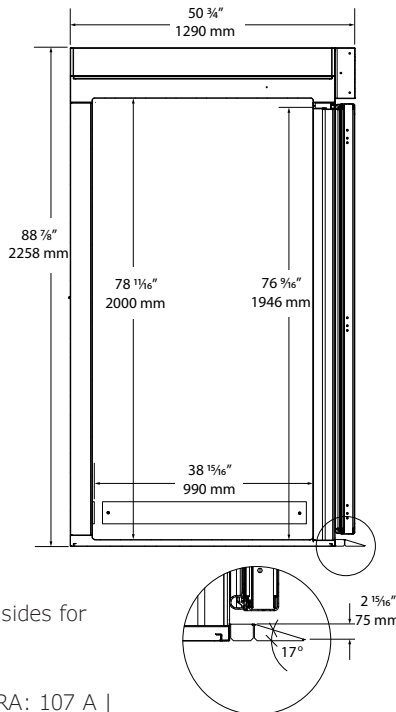

Interior

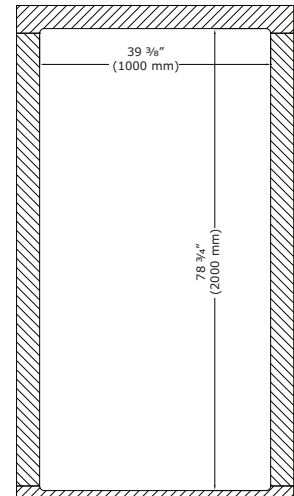

Note: Condensing unit requires clearance of 39 3/8" on all sides for proper ventilation.

Remote condenser unit: 72207.897 BTU/h chilling,
12059.091 BTU/h freezing / 7.5 HP RLA: 23.7 A / LRA: 107 A |
MCA 34.725 A / MOP 58.425 A

Commercial Warranty

3 Year (parts & labor) / 5 year sealed system (parts)

See complete warranty for details

*All tests completed using 2" thick food products

