



BEVERAGE-AIR

Project: _____	AIA#
Item: _____	
Location: _____	SIS#
Approved: _____	

UCFD32AHC UNDERCOUNTER FREEZER WITH DRAWERS

UNDERCOUNTER FREEZER

UCFD32AHC Undercounter Freezer With Drawers
Hydrocarbon Series

MODEL:
UCFD32AHC-2



7 Year Parts/Labor Warranty
7 Year Compressor Warranty

CABINET CONSTRUCTION

- Stainless steel front, sides, top, drawers and grille (galvanized steel back & bottom)
- Interior liner is made of corrosion resistant aluminum
- Full electronic control
- Undercounter feature a 1/2" thick sub-top
- Interior thermometer is standard
- Snap-in drawer gaskets
- Upper and lower pull-out drawers accommodate 6" deep pans
- Stainless steel drawer frames supported on telescoping drawer slides
- Drawer slides include locking mechanism that prevents drawer from being inadvertently pulled off cabinet
- 6" Casters, (2) with brakes standard

OPTIONS & ACCESSORIES

- Stainless steel back
- Stainless steel interior
- 3" Casters
- 6" Legs (stainless steel, black or seismic/ flange)
- Low profile casters
- Roller kit
- Remote option* (see note on back on page)

REFRIGERATION SYSTEM

- Uses environmentally friendly, energy efficient R290 refrigerant, and meets all regulatory requirements for CARB, SNAP, DOE & more
- Adaptive defrost
- Epoxy coated evaporator coil
- Freezers capable of maintaining product temperature of -10°F



Please verify qualifying units by visiting:
www.energystar.gov/cfs

3779 Champion Blvd., Winston-Salem, NC 27105
1-888-845-9800 Fax: 1-336-245-6453
Beverage-Air.com Sales@bevair.com



BEVERAGE-AIR

MODEL	UCFD32AHC-2
EXTERNAL DIMENSIONAL DATA	
Width Overall	32"
Depth Overall with Handle & Bumper	32"
Height Overall with 6" Casters	34 1/2"
Number of Drawers	2
Depth with Drawer Extended	48 1/2"
Drawer Openings	(2) 27 5/8" x 11 3/8"
INTERNAL DIMENSIONAL DATA	
NET Capacity (cubic ft.)	7.2
Internal Width Overall (in)	28"
Internal Depth Overall (in)	15 3/8"
Internal Height Overall (in)	23"
ELECTRICAL DATA	
Full Load Amperes	4.0
REFRIGERATION DATA	
Horsepower	1/3+
Capacity (BTU/Hr)	1184
Heat Rejection (BTU/Hr)	1776
Charge (lbs/grams/ounces)	0.165 / 75 / 2.64
SHIPPING DATA	
Gross Weight - Crated	256 lbs
Height - Crated	35"
Width - Crated	33"
Depth - Crated	35"

*NOTE: Remote units are field wired and come with 6" legs. Refrigerant must be specified at time of order.

We reserve the right to change specifications and product design without notice. Such revisions do not entitle the buyer to corresponding changes, improvements, additions or replacements for previously purchased equipment. Dimensional tolerances +/- 1/4". Metric dimensions (MM).

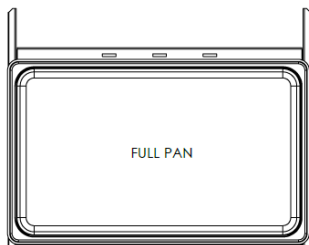

Undercounter Freezer With Drawers Model: UCFD32AHC-2

Model Views

Required Clearance: 3" Bottom & 2" Rear

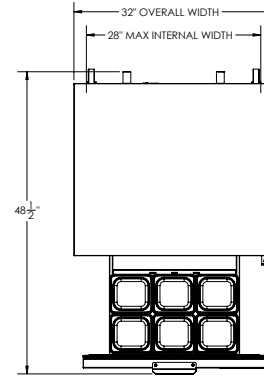

PLAN VIEW

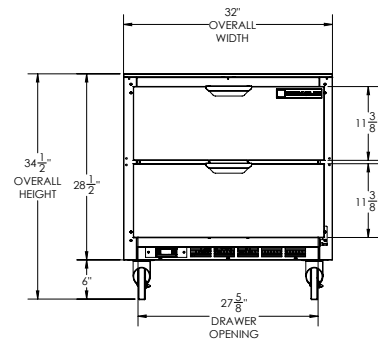

ELEVATION VIEW

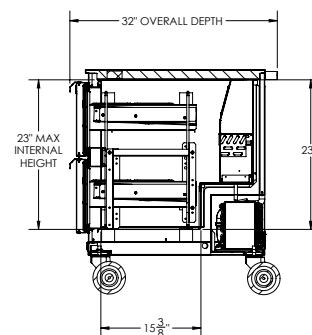

SIDE VIEW

ELECTRICAL CONNECTION



115/60/1
NEMA 5-15P

Unit pre-wired at factory and include 8' long cord and plug set.

