



XAF STATIONS

MODEL: XAFS-183-2

The XAF Station is a heavy duty, manual control oven featuring two XAF convection ovens, stacked on the OST Cadco stand, offering enhanced capacity and efficient cooking.

It's compact and easy-to-manage and perfect for establishments requiring high-volume cooking with minimal space.

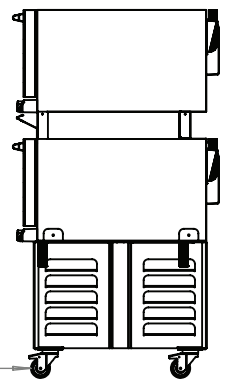
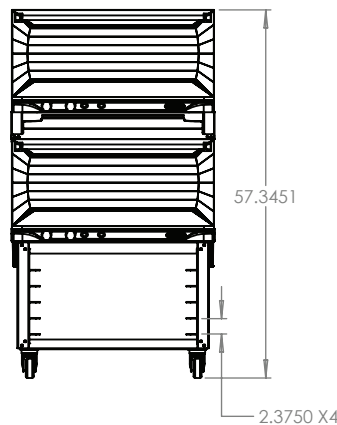
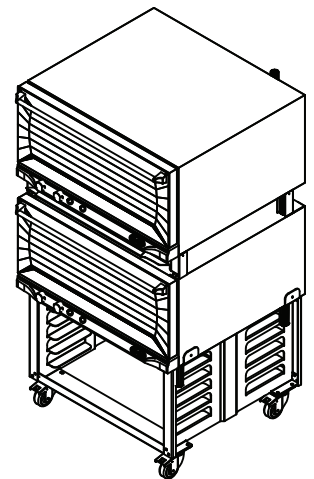
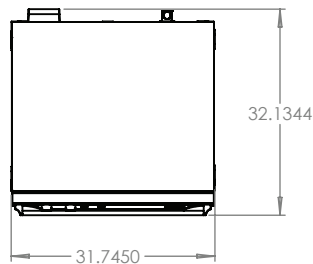

CASTERS
2 LOCKING
2 TOTAL LOCKING

SPEC FOR EACH XAF-183

Unit Dimensions (W" x H" x D"): 31 1/2 x 19 7/8 x 32
Cavity Size (W" x H" x D"): 27 1/4 x 10 x 18 3/4; 3 cft.
(One fan. NEMA L6-30 plug.) Shelves: 3
Volts: 208-240 Watts: 4600 Amps: 20

SPEC FOR CXC 646 (Stacking Kit)

Unit Dimensions (W" x H" x D"): 31.5" x 4"
Stainless front piece with integral columns, heat baffle
Stainless back piece with integral columns
Screws, Bottom oven vent extension & clamp
90 day warranty

SPEC FOR OST-195-CS

Unit Dimensions (W" x H" x D"): 31.71" x 23" x 27"
Handles 5 FULL Size Sheet pans (not included)
Can hold two full size cadco ovens
Short Heavy-Duty Stand w/ Wheels for full size ovens

XAFS-183-2 will ship as two pallets. Pallet #1: 38x35x56 (250lbs) Pallet #2: 38x35x28 (190lbs)

