



# BEVERAGE-AIR

Project: _____	AIA#
Item: _____	
Location: _____	SIS#
Approved: _____	

# WTF36AHC WORKTOP FREEZER

## WORKTOP FREEZER

### WTF36AHC Solid Door Freezer

### Hydrocarbon Series

MODEL:  
WTF36AHC



**7 Year Parts/Labor Warranty**  
**7 Year Compressor Warranty**

### CABINET CONSTRUCTION

- Stainless steel front, sides, doors and grille (galvanized back & bottom)
- Interior liner is made of corrosion resistant aluminum
- Stainless steel top for added durability
- 4" Removable backsplash for flexibility and ease of cleaning
- Full electronic control
- Interior thermometer is standard
- Self-closing doors with 120° stay-open feature, on cartridge style hinges
- Doors opening includes low wattage, anti-condensate heaters
- Magnetic gasket attached to each door for positive seal
- 6" Casters, two (2) with brakes standard
- Four (4) epoxy-coated steel wire shelves
- Field-reversible doors (hinge kit not included)

### OPTIONS & ACCESSORIES

- Stainless steel back
- Stainless steel interior
- 16 Gauge stainless steel top
- Additional shelves
- Shelf clips
- Glass door option
- Right or left hinged door
- Locks (solid doors only)
- Bun rack
- Wire shelf divider
- Cutting board
- 3" Casters
- 6" Legs (stainless steel, black or seismic/flange)
- Low profile casters
- Roller kit
- Remote option\* (see note on back on page)

### REFRIGERATION SYSTEM

- Uses environmentally friendly, energy efficient R290 refrigerant, and meets all regulatory requirements for CARB, SNAP, DOE & more
- Adaptive defrost
- Epoxy coated evaporator coil
- Freezers capable of maintaining product temperature of -10°F



  
 Please verify qualifying units by visiting:  
[www.energystar.gov/cfs](http://www.energystar.gov/cfs)

3779 Champion Blvd., Winston-Salem, NC 27105  
 1-888-845-9800 Fax: 1-336-245-6453  
 Beverage-Air.com Sales@bevair.com



# BEVERAGE-AIR

MODEL	WTF36AHC
<b>EXTERNAL DIMENSIONAL DATA</b>	
Width Overall	36"
Depth Overall with Handle & Bumper	32"
Height Overall with 6" Casters	39 5/8"
Number of Doors	2
Depth with Door Open 90°	46 1/4"
Door Openings	13 3/4" x 21 7/8"
<b>INTERNAL DIMENSIONAL DATA</b>	
NET Capacity (cubic ft.)	8.69
Internal Width Overall (in)	32"
Internal Depth Overall (in)	15 3/8"
Internal Height Overall (in)	23"
Number of Shelves	4
<b>ELECTRICAL DATA</b>	
Full Load Amperes	4.0
Voltage	115/60/1
Nema Plug (8' cord)	5-15P
<b>REFRIGERATION DATA</b>	
Horsepower	1/4
Capacity (BTU/Hr)	1418
Heat Rejection (BTU/Hr)	2127
Charge (lbs/grams/ounces)	0.165 / 75 / 2.64
<b>SHIPPING DATA</b>	
Gross Weight - Crated	232 lbs
Height - Crated	36"
Width - Crated	40"
Depth - Crated	32"

\*NOTE: Remote units are field wired and come with 6" legs. Refrigerant must be specified at time of order.

We reserve the right to change specifications and product design without notice. Such revisions do not entitle the buyer to corresponding changes, improvements, additions or replacements for previously purchased equipment. Dimensional tolerances +/- 1/4". Metric dimensions (MM).

## Worktop Freezer Model: WTF36AHC

### Model Views

Required Clearance: 3" bottom & 2" rear

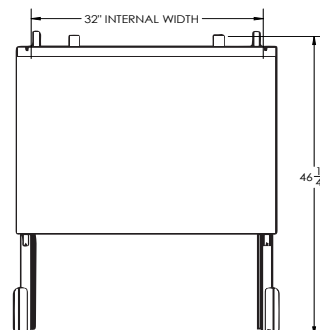

### PLAN VIEW

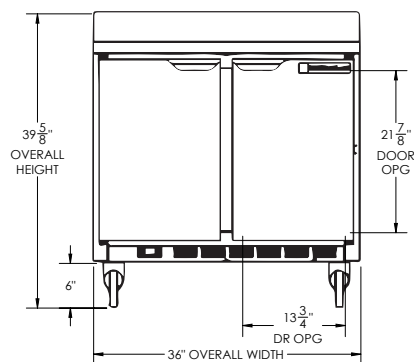

### ELEVATION VIEW

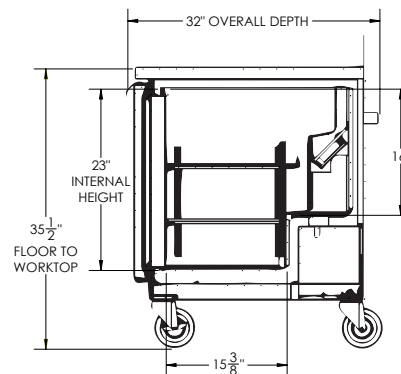

### SIDE VIEW

### ELECTRICAL CONNECTION



115/60/1  
NEMA 5-15P

Unit pre-wired at factory and include 8' long cord and plug set.

