



Technical Data

Hertz	60 Hertz
Phase	1 Phase
Voltage	115 Volts
Access Type	Doors
BTU (LBP)	1739 BTU
Capacity	20.91 cu.ft.
Compressor Location	Rear Mounted
Compressor Style	LMBP
Door Style	Swing
Door Type	Solid / Left & Right
Features	Removable Magnetic Door Gaskets Self-Closing Doors
Horsepower	1/4 HP
Individual Shelf Capacity	66 lb.
Number of Doors	2 Door
Number of Shelves	2 Shelf
Plug Type	NEMA 5-15P
Refrigerant Capacity	5.26 oz.
Refrigerant Type	R-290
Temperature Range	33 - 41 Degrees F
Top Capacity	
Type	Refrigerators
	Pizza prep Table



Plan View

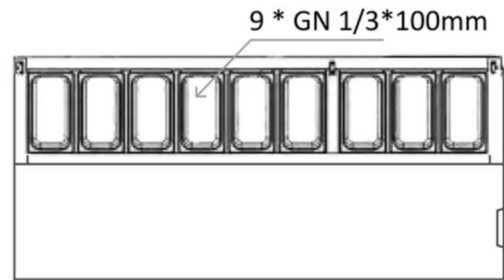
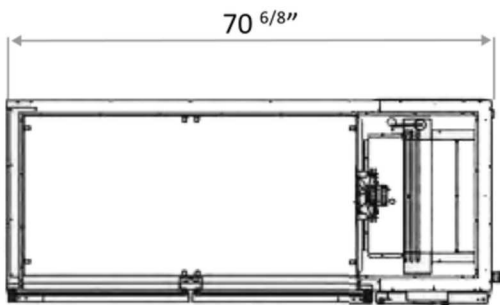
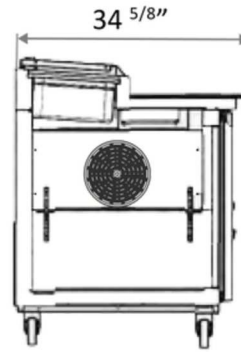
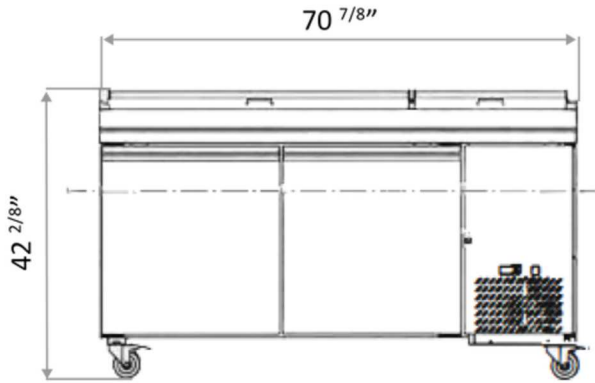



Notes & Details

The Pizza Prep Table with Solid Door is designed for high-demand kitchen environments, combining functionality with a sleek, durable build. Featuring a robust stainless steel interior and exterior, this unit is crafted to withstand the rigors of daily use while maintaining a professional appearance. The reversible doors add flexibility in kitchen setups, and their self-closing mechanism (when opened less than 90°) helps conserve energy by keeping cold air inside.

Ease of maintenance is a priority: the inner box has smooth, curved edges that make cleaning simple and quick. Additionally, the magnetic sealing strip effectively retains cold air and can be removed without any tools, ensuring easy upkeep. For added security, each door includes a lock and key, while the handle is customizable to fit specific aesthetic or ergonomic preferences.

The digital thermostat, made by top Italian brands like Dixell, Carel, or Eliwell, ensures precise temperature control, crucial for keeping ingredients fresh. Powered by a high-quality Embraco compressor, this table provides reliable performance with optimal cooling efficiency.

Optional Upgrades: For even more customization, consider upgrading to German EBM fans, an automatic defrost system, and adjustable feet or lockable casters, enhancing both flexibility and performance.

ETL Sanitation



This product has been certified by ETL, a division of the Intertek Group, to meet applicable sanitation standards required for use in the United States and Canada.

5-15P



This unit comes with a NEMA 5-15P plug

ETL, US



This product has been certified by ETL, a division of the Intertek Group, to meet applicable electrical product safety standards required for use in the United States.