

Specification Sheet

FX82G3T Combistar



Capacity

- (8) 18"X26" Full Size Sheet Pans Or (16) 12"X20" Hotel Pan
- 169 Quarts (160 l) - 205 lb (93Kg) Max
- Wide range of accessories for various cooking processes such as grilling, braising or baking

Convection Heat

- 50°F - 572°F (10°C - 300°C)
- 0% - 100% Humidity

Steam

- 86°F - 257°F (30°C - 125°C)

Combination

- 6°F - 482°F (30°C - 250°C)
- 0% - 90% Humidity

Product Description:

- The Angelo Po CombiStar FX is a versatile and advanced cooking system designed to meet the demands of commercial kitchens. With its programmable controls and touch display, this oven allows for precise and efficient cooking.

Cooking Programs:

- 150 cooking programs with 18 steps each
- 76 program automatic clever cooking icon files
- Favorites menu
- Special cooking techniques programs: Holding, Delta T, Low Temperature Cooking, Rethermalization, HACCP Control Management, Hot and Cold Smoking, Vacuum Cooking, Drying, and Advanced Cook & Chill Interface Technology.

Technology and Features:

- USB interface for easy program transfer and updates
- AISI 316L marine grade stainless steel cavity for durability and easy cleaning
- EHO ergonomic hands-free door handle for safe and easy access
- DCR humidity control and management sensor for optimal cooking results
- Auto reverse 5-speed fan and 1 static mode for even cooking and baking
- PDP progressive density 5 point multi-sensor probe for accurate temperature control
- TAS fully automatic self-cleaning washing system for effortless maintenance
- ADC patented drain cleaning system for easy and efficient cleaning
- WDC descale warning indicator for timely maintenance
- APM automatic power management for energy efficiency
- MCF steam cloud escape reduction for a safe and comfortable working environment
- User manual onboard icon for quick reference and troubleshooting
- RDC & EVOS boilerless and efficient steam generation system for efficient and eco-friendly operation
- EVC color graphic shatterproof control display panel for easy navigation and control
- EASYSTAR film & video capability for sharing recipes and tutorials
- Eco Function to reduce energy and water consumption for sustainable cooking.



Specification Sheet - FX82G3T Combistar



Model	FX82G3T Combistar™
Description	COMBICARE All-In-One™ Combi oven, Natural Gas, 92,500 Btu's, 120v/1phase/60 Hz
Full Size Sheet Pans Capacity	8 (18"X26")
Hotel Pan Capacity	16 (12"X20")
1/1 GN Pan Capacity	16 (530x325x65mm)
Half Size Sheet Pan Capacity	8 (18"x13"x1") on wire shelves only (additional wire shelves required for max capacity)
2/1 GN Pan Capacity	8 (650x530x65mm)
Pan Module Distance	2-47/64" (69,5mm)
Product Capacity	169 Quarts (160 l) - 205 lb (93Kg) Max
Gas Power	92,500 BTU (27,1kW) Nat and LPG
Max Connected Pressure NG	10.5" WC
Min Connected Pressure NG	3.5" WC
Max Connected Pressure LPG	13" WC
Min Connected Pressure LPG	8" WC
Hook Up	3/4" NPT
Electric Power	0.9 kW
Voltage	120V
Phase	1ph N
Amperes	7.8 A
Cycle/Hz	60 Hz
AWG	AWG12
Water Inlet	Inlet: 3/4" - Line Pressure: 30 to 60 psi (2 to 4 bar)
Required Chlorine	< 0.1 ppm (mg/l)
Required Chlorides	< 30 ppm (mg/l)
Required Sulphates	< 30 ppm (mg/l)
Recommended Iron	< 0.1 ppm (mg/l)
Recommended Copper	< 0.05ppm (mg/l)
Recommended Manganese	< 0.05ppm(mg/l)
Hardness	3 to 9°f (1.5 to 5 °d; 2.1 to 6.3 °e; 30 to 90 ppm)
Langelier Index	> 0.5
TDS	40 to 150 ppm
Flow Rate	4.6 Gallons/h
PH	7 to 8.5
Water Outlet	1-1/4" Drain with Air Gap
Installation Requirements	Hood Installation is Required for Cooking Smoke. The Oven Must Be Installed Level. Install Water Supply Shut-Off Valve and Back-Flow Preventer
Clearance Requirements: Left Side of Equipment	20" from heat source and 19" recommended for service access. Minimum clearance 6-1/2" - When left side clearance is less than 20" from a heat source, please inquire about a Angelo Po heat shield accessory
Clearance Requirements: Right	Min. clearance 3-57/64"
Clearance Requirements: Top	Min. clearance 12"
Clearance Requirements: Bottom	Min. clearance 4" (also in the Counter Top installations)
Clearance Requirements: Back	20" from heat cooking equipment (oven in the middle of the room) - Min. clearance 4"

It is highly recommended that the Angelo Po reverse osmosis water treatment systems, as well as Angelo Po brand cleaning chemicals (CL55XL detergent and BR55XL brightener) be used and incorporated into all Angelo Po Combistar combi oven installations.

It is the sole responsibility of the owner / operator / purchaser of the Angelo Po equipment, to verify that the incoming water supply is comprehensively tested to meet the Angelo Po water compliance standards, published in this document.

Non-compliance with the Angelo Po water standards noted herein could potentially damage the equipment and/or VOID the original manufacturer's standard warranty.

Specification Sheet

FX82G3T Combistar

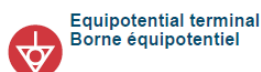
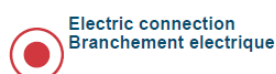
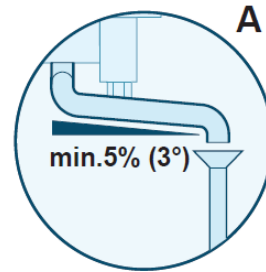
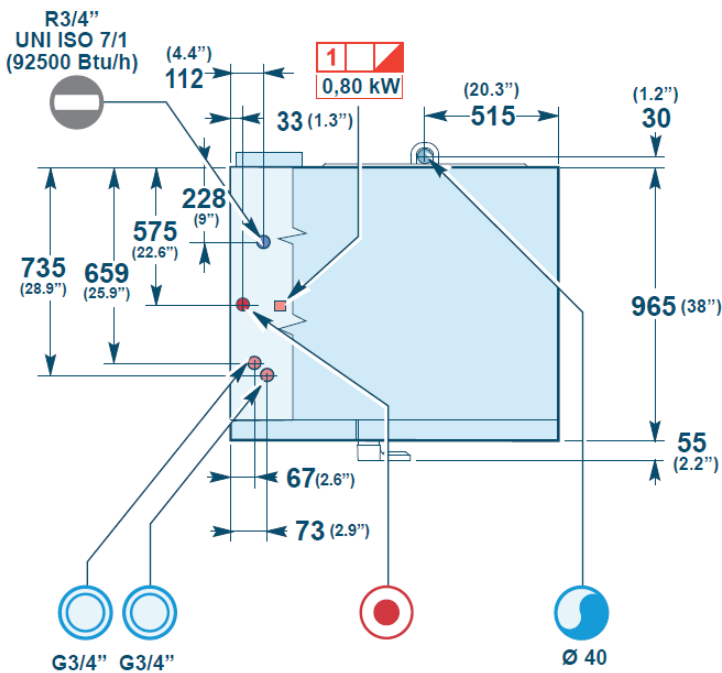
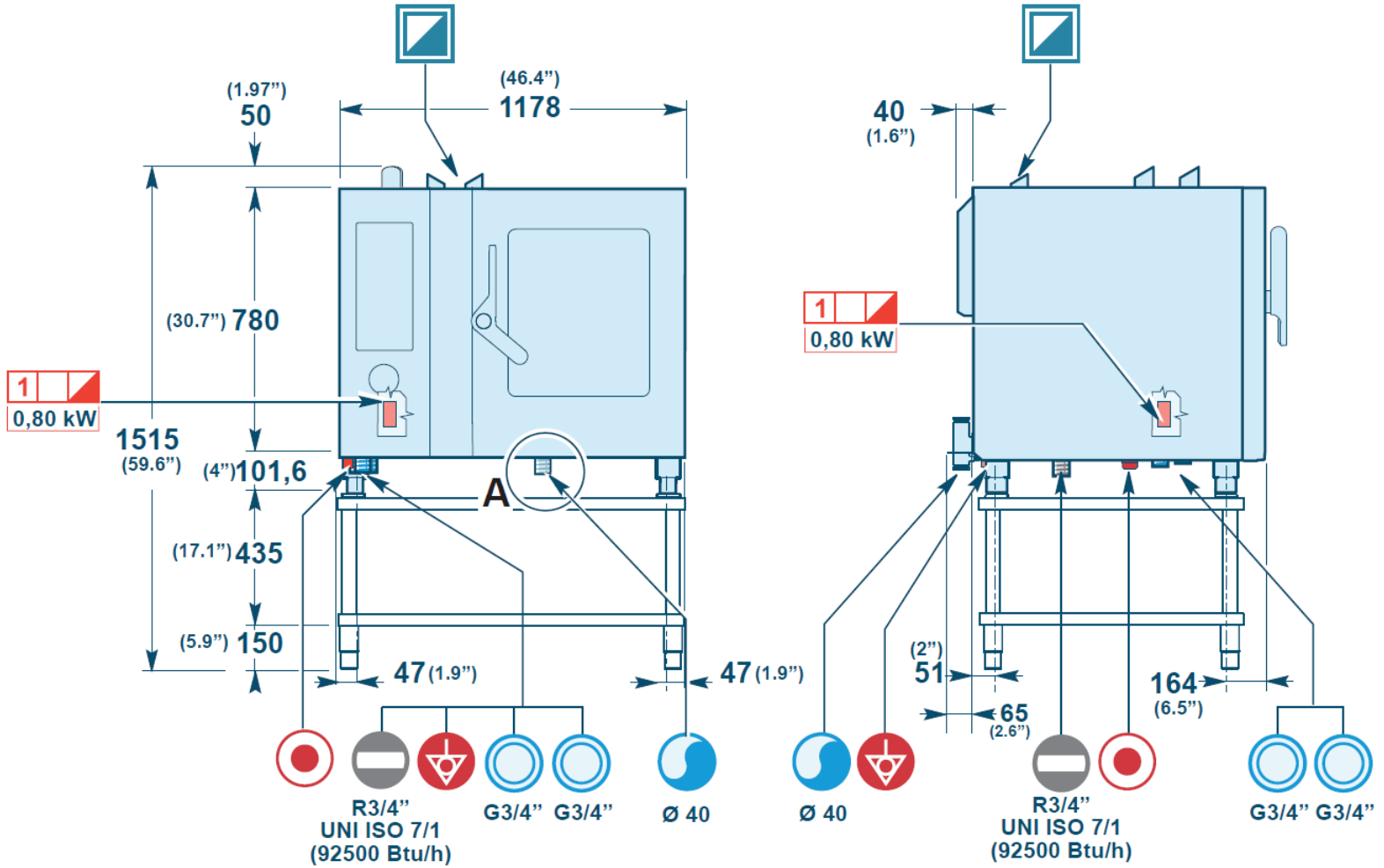

Unit of measurement = mm / in
Unité de mesure = mm / in