



SERVING THE FOOD INDUSTRY SINCE 1951

GLASS DOOR STAINLESS STEEL REFRIGERATOR

ITEM: 51024
MODEL: RE-CN-0021-G-HC

51026
RE-CN-0041-G-HC

51028
RE-CN-0067-G-HC



The perfect solution to exhibit cold merchandise and boost your sales!

FEATURES

- Sleek and modern design
- The stainless steel exterior is durable, easy to clean and maintain.
- Digital temperature controller and display
- Manual defrost allows controlling the frequency and duration of the defrost cycle.
- Ventilated cooling system ensures even temperature distribution and fast cooling recovery.

Telephone: 1-800-465-0234

Fax: (905) 607-0234

Email: sales@omcan.com

Website: www.omcan.com



Authorized Dealer



29" – 1 Glass Door

ITEM: 51024 MODEL: RE-CN-0021-G-HC



TECHNICAL SPECIFICATIONS

Item	51024
Model	RE-CN-0021-G-HC
Net Volume	651.3 L / 23 cu. ft.
Temperature Range	33°- 41°F / 0.5°C to 5°C
Max Ambient Temp	89.6°F / 32°C
Refrigerant	R290
Cooling System	Ventilated
Power	1/5 HP
Electrical	115V / 60Hz / 1Ph
Amps	3.6A
Number of Doors	1
Number of Shelves	3
Shelf Capacity	583 L / 20.6 cu. ft.
Exterior Dimensions (WDH)	29" x 32.3" x 82.5" 736 x 818 x 2095 mm
Interior Dimensions (WDH)	24.4" x 27" x 53.5" 620 x 688 x 1360 mm
Packaging Dimensions (WDH)	34" x 30.3" x 84.4" 770 x 865 x 2145 mm
Net Weight	302 lb. / 137 kg
Gross Weight	341.7 lb. / 155 kg

TECHNICAL DRAWING & DIMENSIONS

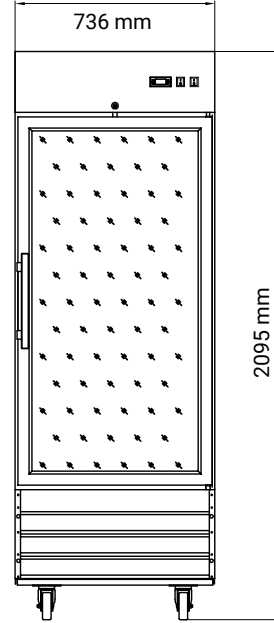

FRONT VIEW

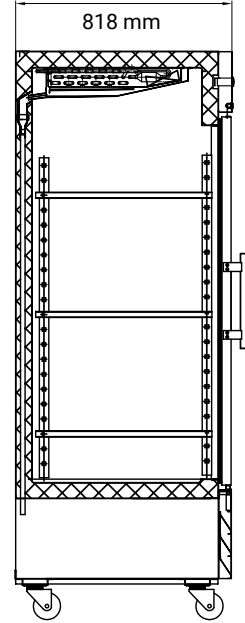

SIDE VIEW

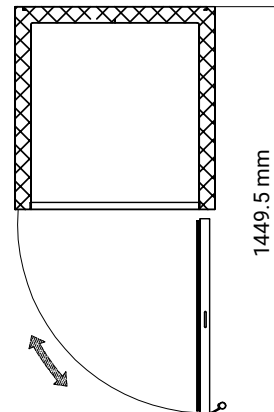

TOP VIEW

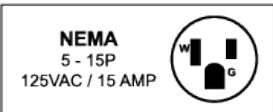

Telephone: 1-800-465-0234

Fax: (905) 607-0234

Email: sales@omcan.com

Website: www.omcan.com



Intertek



Intertek



54" – 2 Glass Doors

ITEM: 51026 MODEL: RE-CN-0041-G-HC



TECHNICAL SPECIFICATIONS	
Item	51026
Model	RE-CN-0041-G-HC
Net Volume	1330.9 L / 47 cu. ft.
Temperature Range	33°- 41°F / 0.5°C to 5°C
Max Ambient Temp	89.6°F / 32°C
Refrigerant	R290
Cooling System	Ventilated
Power	1/3 HP
Electrical	115V / 60Hz / 1Ph
Amps	6.2A
Number of Doors	2
Number of Shelves	6
Shelf Capacity	1169 L / 41.3 cu. ft.
Exterior Dimensions (WDH)	54" x 32.3" x 82.5" 1371 x 818 x 2095 mm
Interior Dimensions (WDH)	49.4" x 27" x 53.5" 1255 x 688 x 1360 mm
Packaging Dimensions (WDH)	34.6" x 56.5" x 84.4" 1435 x 880 x 2145 mm
Net Weight	469.6 lb. / 213 kg
Gross Weight	553.4 lb. / 251 kg

TECHNICAL DRAWING & DIMENSIONS

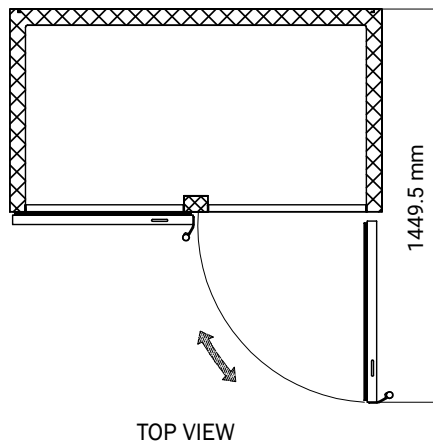
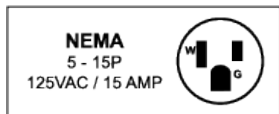
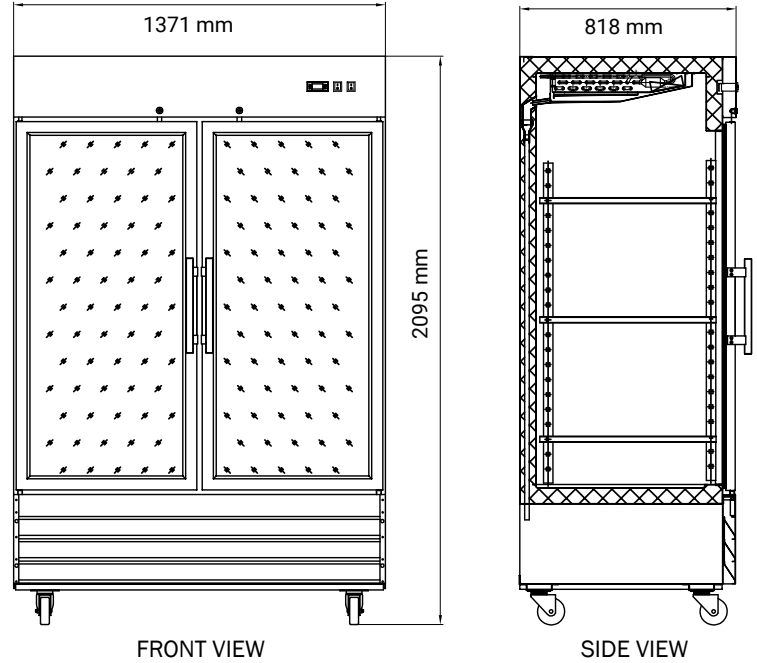

Telephone: 1-800-465-0234

Fax: (905) 607-0234

Email: sales@omcan.com

Website: www.omcan.com



81" – 3 Glass Doors

ITEM: 51028 MODEL: RE-CN-0067-G-HC



TECHNICAL SPECIFICATIONS

Item	51028
Model	RE-CN-0067-G-HC
Net Volume	2038.8 L / 72 cu. ft.
Temperature Range	33° - 41°F / 0.5°C to 5°C
Max Ambient Temp	89.6°F / 32°C
Refrigerant	R290
Cooling System	Ventilated
Power	3/4 HP
Electrical	115V / 60Hz / 1Ph
Amps	8.5A
Number of Doors	3
Number of Shelves	9
Shelf Capacity	1883 L / 66.5 cu. ft.
Exterior Dimensions (WDH)	80.9" x 32.2" x 82.5" 2054 x 818 x 2095 mm
Interior Dimensions (WDH)	76.3" x 27" x 53.5" 1938 x 688 x 1360 mm
Packaging Dimensions (WDH)	34.6" x 83.7" x 84.5" 2125 x 880 x 2145 mm
Net Weight	615.1 lb. / 279 kg
Gross Weight	694.5 lb. / 315 kg

TECHNICAL DRAWING & DIMENSIONS

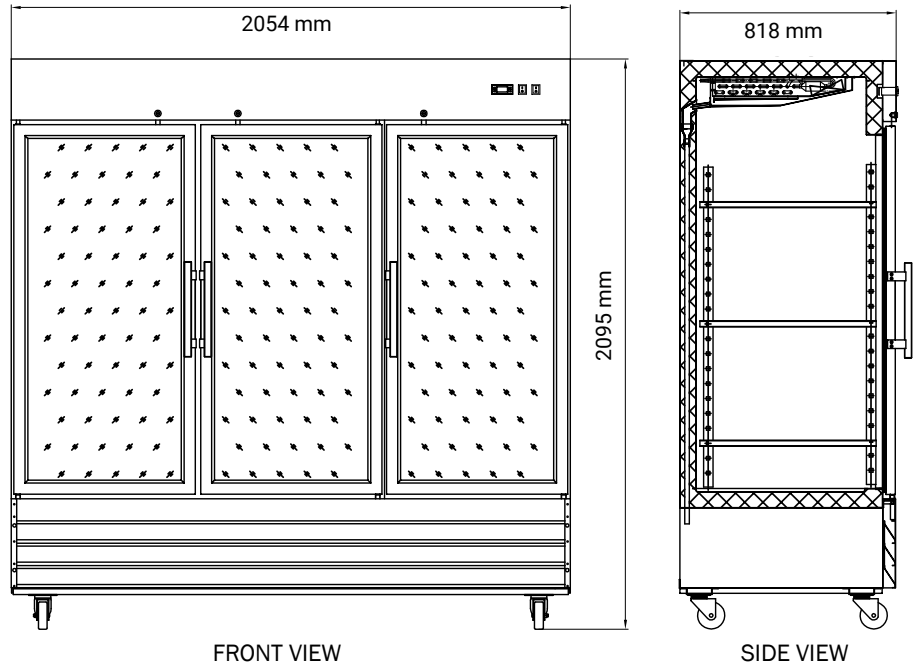

FRONT VIEW

SIDE VIEW

NEMA
5 - 15P
125VAC / 15 AMP

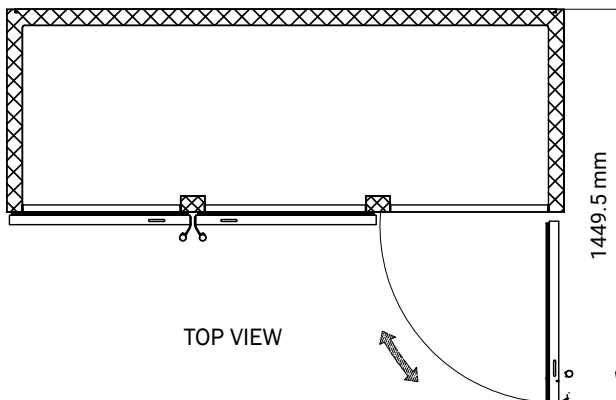

TOP VIEW



Telephone: 1-800-465-0234

Fax: (905) 607-0234

Email: sales@omcan.com

Website: www.omcan.com

