

Item #:	_____	Qty #:	_____
Model #:	_____		
Project #:	_____		



LR4

**FEATURES:**

- Curved top design.
- Heavy duty welded construction with 6 cross supports.
- Heavy duty 5" stem bolted swivel casters.
- 1 1/2" Ribbed Angles.

**CONSTRUCTION:**

Fully welded 1" square tubing ladder assembly.

**MATERIAL:**

6063-T52 extruded aluminum angles, upright tubing, and support pieces.



LR2

MODEL #	Lug Capacity	Overall Size L x W x H	Wt.
LR6	6	19" x 26" x 69 3/4"	23 lbs.
LR4	4	19" x 26" x 52 3/4"	21 lbs.
LR2	2	19" x 26" x 31 3/4"	18 lbs.

# DIMENSIONS and SPECIFICATIONS

TOL ± .500"

ALL DIMENSIONS ARE TYPICAL

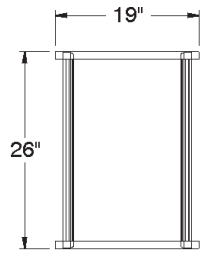

LR2

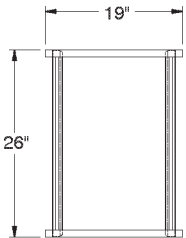
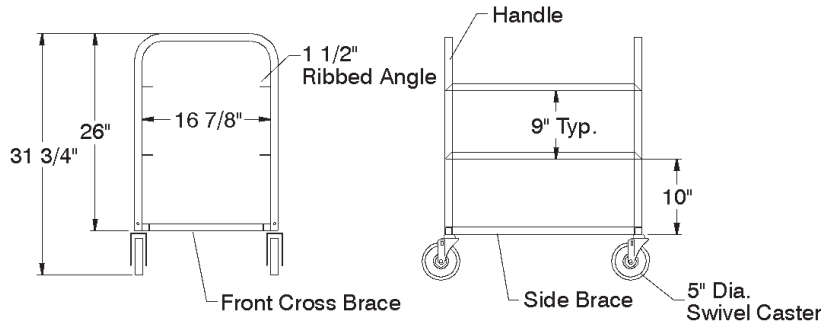

LR4

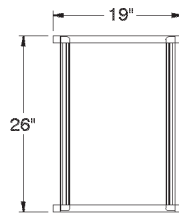
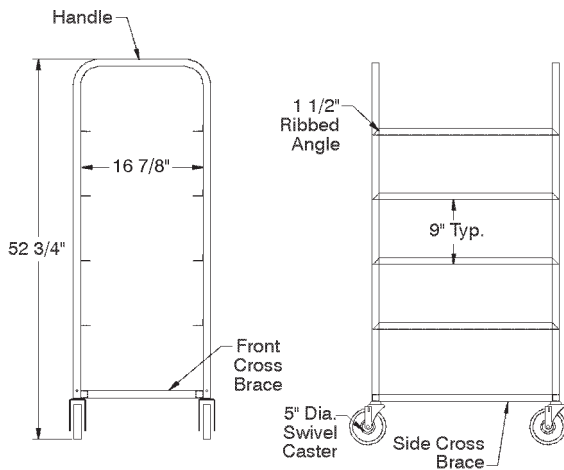

LR6

