

Refrigeration Equipment

3-Door Full Height Freezer 81" Long

ITEM # _____

MODEL # _____

NAME # _____

SIS # _____

AIA # _____



738246 (KCHRI81R3DF)

3-Door Full Height Freezer 81" Long

Short Form Specification

Item No. _____

3 full door freezer with exterior top, back, and bottom panels in galvanized steel, exterior side panels in 430 stainless steel; interior back, side, top and bottom panels in 304 stainless steel. Control with cabinet temperature display. Self-closing and on-site reversible door feature with lock and key. R290 gas in the refrigeration circuit. ETL Safety and Sanitation certifications. 3/5 Years warranty.

Main Features

- External temperature display.
- Removable gasket for easy cleaning operations.
- Fin & Tube Condenser improves performance in high temperature environments.
- Automatic Defrost Cooling System provides worry-free performance.
- Electronic Temperature Control, quick and simple to set, with control display for easy monitoring.
- Heavy duty Vinyl coated steel shelves.
- Cabinet completely insulated with high density polyurethane for low environmental impact.
- Bottom mounted cooling unit slides out for easy access and cleaning.

Construction

- Lockable door.
- Self-closing door with 90-degree stay-open feature.
- Heavy duty casters.
- Pre-wired heavy duty power cord.
- Heavy duty door hinges.
- Magnetic gasket removable without tools for easy cleaning.

Sustainability

- High efficiency components to minimize the energy consumption still guaranteeing the highest performances.
- Interior LED light to save energy and for best internal visibility.

Optional Accessories

- 1 ADJUSTABLE FOOT PNC 206445
- Shelf for 54" and 81" (left/right) Reach-In (Solid Door) PNC 880591
- Middle Shelf for 81" Reach-Ins (Solid Door) PNC 880592
- Shelf clips (4-pack) PNC 880611
- Sheet Pan Rack Fits KCHRI Models PNC 880622

APPROVAL: _____

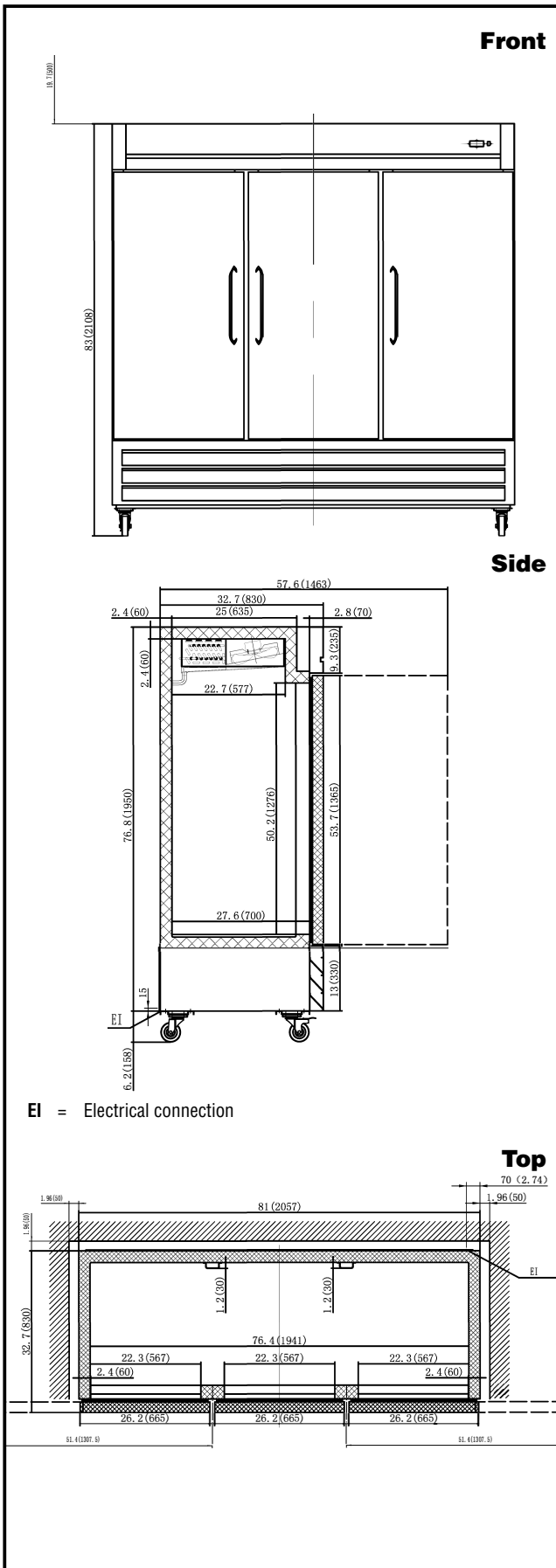

Electric

Supply voltage:

738246 (KCHRI81R3DF) 115-230 V/1 ph/60 Hz

Electrical power, max:

1 kW

Plug type:

USA NEMA L14-20P

Capacity:

Gross capacity: 72 cu.feet

Key Information:

Door hinges:	1 Left+2 Right
External dimensions, Width:	81 " (2057 mm)
External dimensions, Depth:	32 11/16" (830 mm)
External dimensions, Height:	83 " (2108 mm)
Number and type of doors:	3 Full
Internal Dimensions (depth):	27 1/2" / (698.5 mm)
Internal Dimensions (height):	50 3/16" / (1275.08 mm)
Internal Dimensions (width):	76 3/8" / (1940.56 mm)
Shipping height:	84 5/8" (2150 mm)
Shipping weight:	809 lbs (367 kg)
Shipping volume:	139.55 ft ³ (3.95 m ³)
Number and type of grids (included):	9 - Coated Steel
Type of external material:	Stainless Steel
Type of internal material:	304 AISI
Warranty:	3 / 5 years
Approvals	ETL C&US;ETL SANITATION

Refrigeration Data

Compressor power:	1 ½ hp
Operating temperature min.:	-10.01 °F
Operating temperature max.:	0 °F
Condenser type:	Fin & tube
Defrost type:	Auto Defrost

Sustainability

Current consumption:	9 Amps
Refrigerant type:	R290
GWP Index:	3
Refrigerant weight:	150 g



Refrigeration Equipment 3-Door Full Height Freezer 81" Long

The company reserves the right to make modifications to the products without prior notice. All information correct at time of printing.