

Project _____

Item Number _____

Quantity _____

SRMF20+ Mixer



*Shown with optional PTO

20 Quart (qt.) Floor Model Mixer

MADE IN THE USA

Model:

- SRMF20+: 20 qt. FLOOR MODEL MIXER (WITH OR WITHOUT PTO HUB)



Floor Model Mixer

Standard Accessories:

- 20 qt. stainless steel bowl
- Dough hook
- Batter beater
- Wire whip
- Ingredient chute
- Bowl scraper

Optional Accessories:

- 15 minute timer
- Heavy duty SS wire whip
- Sweet dough beater
- Splash ring
- 20 qt. pastry knife
- Four wing beater
- Cover

Optional Attachments:

- #12 Power Take-Off (PTO) hub
- VS9 vegetable slicer with adjustable knife
- VS9H vegetable shredder with plate holder and 3/16" plate (additional plate size variations, grater plates, and julienne plate available)
- ALMFC12 meat and food grinder

Warranty:

- Two year, on-site parts and labor

Features:

- 1/2 hp capacitor start motor
- Variable Speed Drive: 4 fixed speeds or any speed in-between
- Change speeds without having to stop the mixer
- Two-piece, stainless steel, dishwasher safe safety guard
- Heavy-duty stainless steel bowl
- Interlock switches protect operator from injury if safety guard is open or bowl is lowered
- Hardened alloy gears in transmission
- Durable NSF approved hybrid epoxy/polyester powder coat finish

Univex Corporation



WE RAISE THE BAR. WE SET THE STANDARD.

20 Quart Floor Model Mixer

SRMF20+

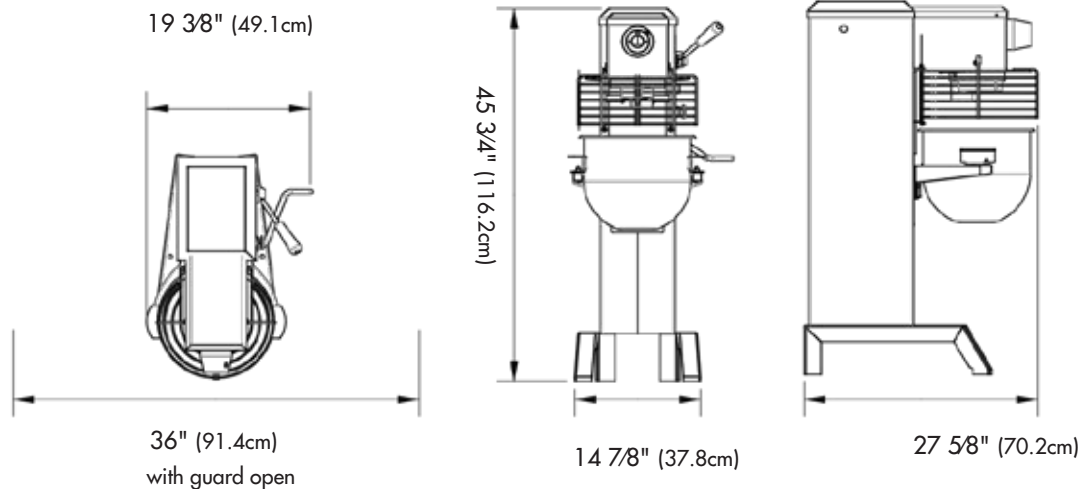

*Shown with optional PTO and timer

Shipping Information		
Net Weight	Shipping Weight	Overall Dimensions
230 lbs. (104.3Kg)	284 lbs. (128.8Kg)	56" (142.2cm) H x 36" (91.4cm) W x 33" (83.8cm)
The weight and dimensions of the pallet are included in the weight and dimensions above.		

Electrical Information (60Hz)				
Attached 6 foot cord				
	Voltage	Phase	AMPS	NEMA
Standard	115	1	10.6	5-15P
Optional	208-240	1	4.8-5.3	6-15P

Bowl Capacity: 20 qts. (18.9 liters)

Motor: 1/2 hp capacitor start

Controls: Momentary contact stop & start buttons and contactor

Bowl Lift: Ergonomic hand operated crank, self locking in top and bottom position

Transmission: Featuring hardened alloy gearing and torque sensing variable speed pulleys

Mixer Speeds				
Speed	1	2	3	4
Beater Shaft (RPM)	135	260	435	528
PTO (RPM)	62	133	198	238



Univex Corporation
www.Univexcorp.com

3 Old Rockingham Rd
Salem, NH 03079
United States of America

TEL: (800)258-6358
INTL TEL: (603)893-6191
FAX: (800)356-5614
INTL FAX: (603)893-1249