



YOU CAN TRUST

## SLICERS

### AF300 - AF350



**SW** Swedlinghaus

AF300



AF350



### STANDARD FEATURES

These compact, durable and quiet Italian Slicers highlight features designed for smooth operation, precise cutting, and ease of maintenance. The focus on high-quality materials and construction suggests a professional grade and high end consumer product.

- Designed to fit in small spaces: compact footprint, making it suitable for kitchens or businesses with limited counter space maintaining optimal cutting performance.
- Anodized cast aluminum alloy construction: this combination allows for a robust and long-lasting machine.
- Belt/driven transmission: belt drives are known for their quiet operation and smooth power transfer.
- Silent/running asynchronous motor: asynchronous motors are generally quieter and more efficient than other motor types, reinforcing the emphasis on quiet operation.
- Forged and hardened steel blade: Forging and hardening create a strong, durable, and sharp blade that can maintain its edge over time. This is crucial for clean and precise slicing.
- Carriage running on self/lubricating bushes: Self-lubricating bushes (or bearings) reduce friction and wear, ensuring smooth carriage movement and minimizing maintenance.
- Aluminum feed plate equipped with special sliding grooves to reduce friction: This feature further enhances smooth operation by minimizing resistance as food is pushed towards the blade.
- Cast/in aluminum sharpener assembly: An integrated sharpener made of cast aluminum ensures easy and convenient blade sharpening, maintaining optimal cutting performance.

ILLUSTRATIVE PHOTO, ACTUAL PRODUCTS AND ACCESSORIES ARE SUBJECT TO CHANGE WITHOUT NOTICE



**Skyfood Equipment LLC**  
175 SW 7th Street, Ste 2416  
Miami, FL 33130

**Toll Free:**  
1-800-503-7534  
sales@skyfood.us

[www.skyfood.us](http://www.skyfood.us)



Follow us to keep up to date with the latest news and offers

/SkyfoodEquipment

/SkyfoodEquipment

/SkyfoodEquipment



YOU CAN TRUST

## SLICERS

### AF300 - AF350



#### DIMENSIONS AF300

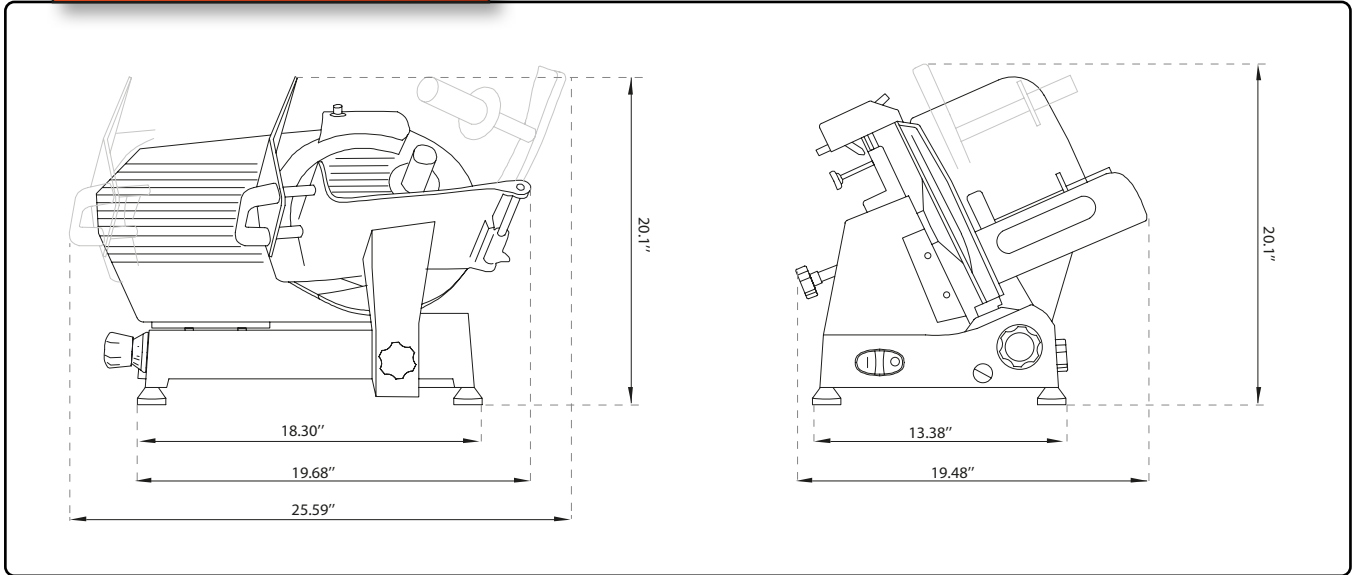

#### DIMENSIONS AF350

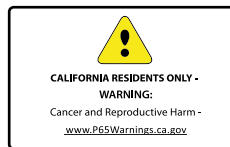
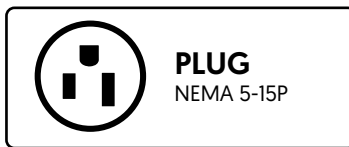
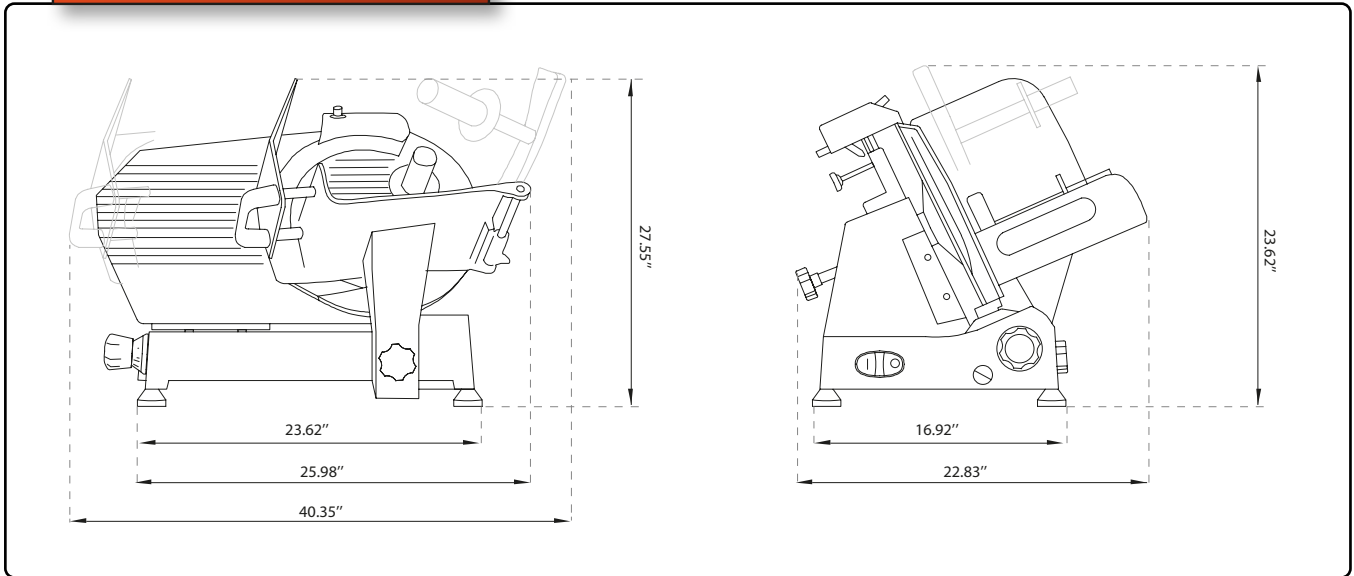

Item	Voltage	Power Rating	Dimensions W x D x H	Weight (Net x Ship)	Blade Size	Carriage Dimensions	Cutting Capacity	Cutting Thickness	PLUG
AF300	110 V	1/3 HP	25.5" x 19.5" x 20.1"	51 lb x 56 lb	12"	8.7" x 10.4"	8.7" x 8.7" (8.7" dia.)	5/8"	NEMA 5-15
AF350	110 V	1/2HP	40.35" x 22.83" x 23.62"	85 lb / 90 lb	14"	12" x 14"	11.81" x 9.84" (10" dia.)	5/8"	NEMA 5-15

ILLUSTRATIVE PHOTO, ACTUAL PRODUCTS AND ACCESSORIES ARE SUBJECT TO CHANGE WITHOUT NOTICE



**Skyfood Equipment LLC**  
175 SW 7th Street, Ste 2416  
Miami, FL 33130

**Toll Free:**  
1-800-503-7534  
sales@skyfood.us

[www.skyfood.us](http://www.skyfood.us)



Follow us to keep up to date with the latest news and offers

[/SkyfoodEquipment](#)

[/SkyfoodEquipment](#)

[/SkyfoodEquipment](#)