

Type: Duck Oven

Model: DCK1300

The Beech DCK1300 Duck Oven is manufactured from a high grade castable ceramic material and completely enclosed in a housing of 5mm (1/4") mild steel. This mild steel outer casing and incorporated lifting hooks make installation easy which reduces potential damage to the oven. The inside diameter of the oven is 1300mm (51") and it has a 1.33m² (14.3ft²) floor area. This style of oven can be fired using wood, gas back-up or full gas.

The spectacular performance of a Beech Oven is a result of the huge thermal mass of the unique ceramic cast interior. Beech Ovens have **TWICE** the mass (*thermal mass*) of any other pre-cast oven on the market.

The floor surface of the oven (*stone hearth*) is constructed using high quality 75mm (3") thick Fire bricks, renowned for their excellent cooking attributes and incredible wear resistance. The use of bricks eliminates the unsightly cracking associated with one piece floors. The bricks sit upon a 25mm (1") VF insulating board and a further 5mm (1/4") reinforced mild steel base.

The unique three (3) piece oven design allows all Beech Duck Ovens to be installed through an 1100mm (43") doorway. All Beech Ovens can be installed without the use of a crane therefore significantly reducing the costs of installation. The oven body comes with an exclusive 4 year guarantee.

The oven can be installed within 75mm (3") (*including 50mm (2") of insulating wool and 25mm (1") air gap*) of non-combustible material (*check local building and fire codes*). The oven exhausts through a spigot above the oven mouth. The oven must be vented in accordance with local and/or national codes. Refer to "Duct Design Options" or for more information, refer to the Installation and Operation Manual located on our website www.beechovens.com
Allow a 600mm x 600mm (24" x 24") ventilation access panel into the underside of the oven for secondary air to the gas burner (*if applicable*).

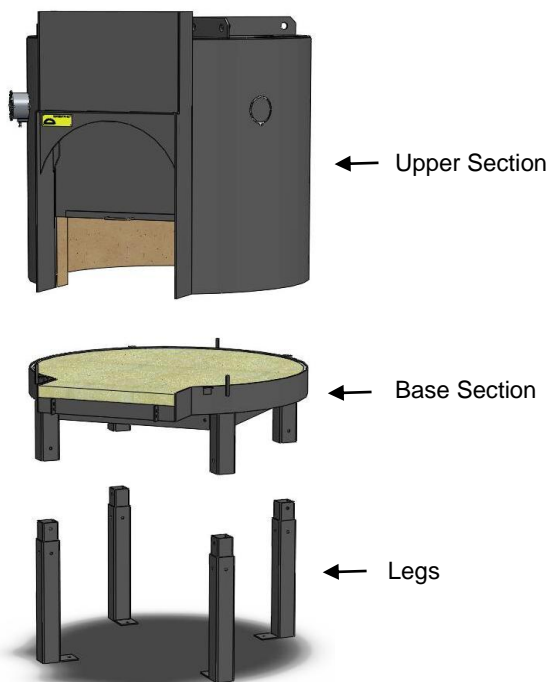
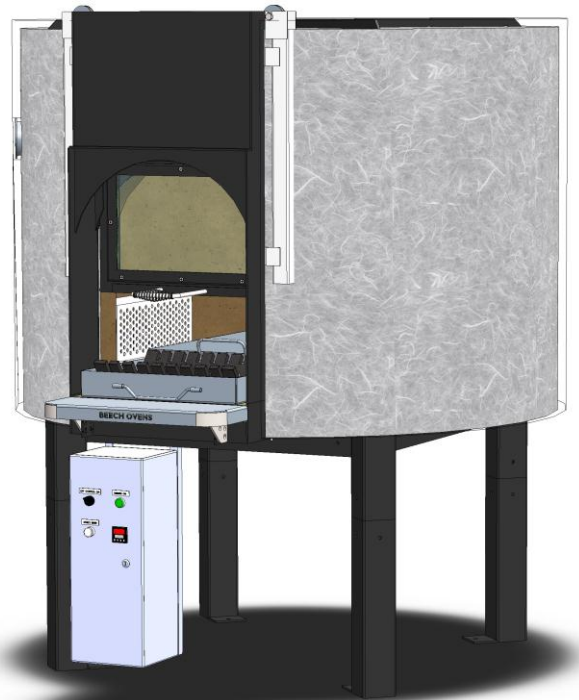

Unique Features

- Wood and/or thermostatically controlled gas system.
- Easy installation into most areas (*three (3) piece assembly*).
- Sliding door for easy access to hanging rails.
- Any gas type – Specify at order time.
- Internal spotlight.
- SS Drip Tray, Fire Tray and Cast Iron Fire Grate.
- Tool Kit including hanging hooks and duck retriever.

Optional Accessories

- Viewing window available in any location.
- Stainless Steel Hearth.
- Thermostatically controlled Aeromatic burner.
- Exhaust fan/Hood.
- Service panels, hearths, lintels extensions.

Approximate Duck Capacity

The DCK1300 will accommodate approximately 12 ducks at any one time. Approximate cooking time for full capacity is 80 minutes.

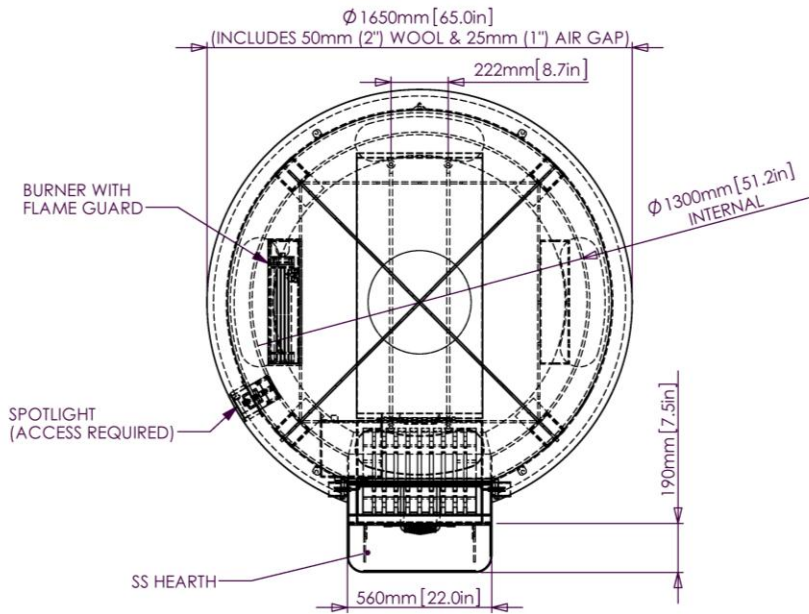

NOTES:

CONNECTION TO APPROVED FLUE/DUCTING REQUIRED.
BEECH OVENS RECOMMEND INSTALLATIONS UNDER
AN APPROVED CANOPY.
(CHECK LOCAL CODES AND REGULATIONS)

SERVICES REQUIRED - SEE BLUE TEXT

THE OVEN IS DELIVERED IN THREE (3) SECTIONS:
UPPER SECTION - Approx 1100kg (2420lbs)
BASE SECTION - Approx 500kg (550lbs)
LEGS - Approx 10kg EACH (22lbs)

TOTAL WEIGHT = Approx 1700kg (3740lbs)

FOR INSTALLATION INSTRUCTIONS SEE INSTALLATION
AND OPERATION MANUAL

SPOTLIGHT
(ACCESS REQUIRED)

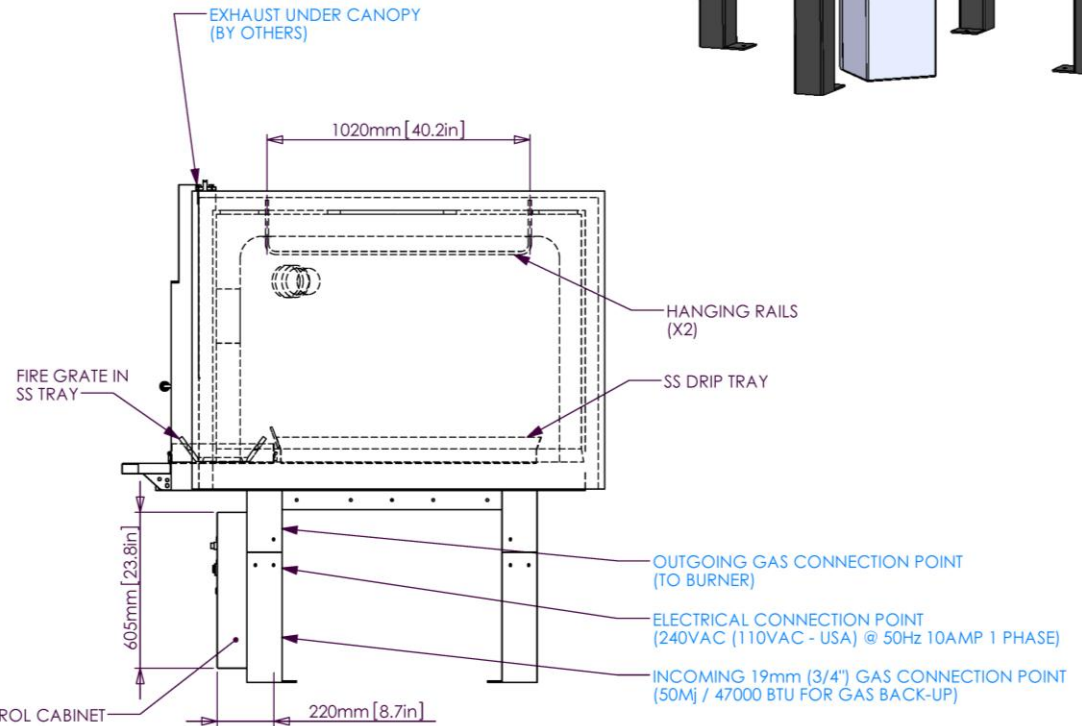
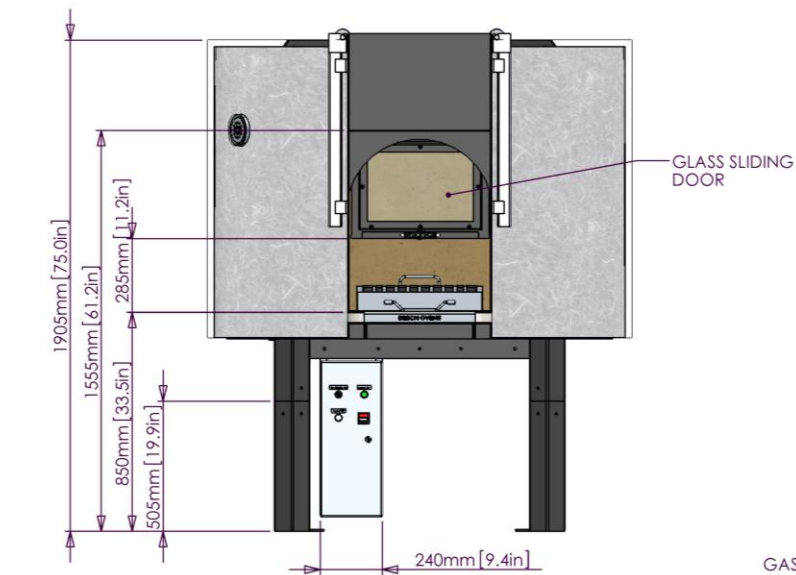
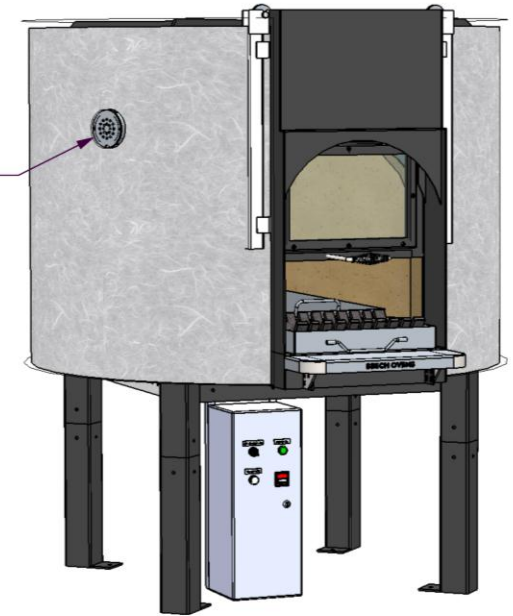

0	ISSUED FOR CONSTRUCTION		
REV.	DESCRIPTION OF CHANGES	DATE	CHANGED BY



Drawn S Trood	Checked	Scale 1:20	Date 19/01/2012
DUCK OVEN Ø1300 (51") INTERNAL GBL - GAS BACK-UP LEFT SS HEARTH_SPOTLIGHT(L)			 A3 NTS - SITE MEASURE