



AMERICAN EAGLE[®]
FOOD MACHINERY, INC.

AE-80N4A
80 Quart Hybrid Drive
Planetary Mixer w/
Power Lift

773.376.0800 (P) • 773.376.2010 (F) • 3131 S. Canal St. Chicago, IL 60616

Lower Your Total Cost Of Ownership With American Eagle® Mixers! All-Inclusive Accessories, Competitive Pricing, And Reliability Make Us The Value Leader In The Industry.

Quality Design

- Powerful 3 HP Motor, 220V/60Hz/3Phase,
- Industry Standard #12 Hub For Additional Accessories
- Hybrid Belt And Gear Driven Transmission For Extra Reliability And Lower Maintenance Costs
- Precision Milled Heat Treated Steel Alloy Gears And Shafts
- Heavy Duty Cast Iron Construction, NSF Approved Heat Treated Enamel Grey Paint Resists Rust, Scratches, And Dents
- ETL Certified To NSF No. 8, CSA, CE Standards
- Heavy Duty, 7 Foot 4 Wire Power Cable*



Standard Features

- Power Lift System
- 15 Minute Automatic Timer
- 4 Fixed Speeds
- Stainless Steel Safety Guard With Auto-Shutoff
- 1 Year Limited Warranty

Standard Accessories

- High Polish 80 Quart Stainless Steel Bowl
- Aluminum Dough Hook
- Stainless Steel Wire Whip
- Aluminum Beater
- Bowl Truck



Optional Accessories

- AE-G12NH Meat Grinder Head
- AE-TS12H Meat Tenderizer
- AE-VS12NH Vegetable Processor
- AE-JS12H Jerky Slicer
- AE-MC12NH Meat Cutter



Proud Member of:
NAFEM
 North American Association of
 Food Equipment Manufacturers

Quality • Value • Reliability



AMERICAN EAGLE
FOOD MACHINERY, INC.

AE-80N4A
80 Quart Hybrid Drive
Planetary Mixer w/
Power Lift

sales@ameagle.biz • www.americaneaglemachine.com

American Eagle® 80 Quart Planetary Mixers Are Perfect For Handling Heavier Doughs In A Restaurant, Bakery, Donut, Or Pizza Business! Call Us To Find Out More About Our Full Line Of Mixers And Optional Accessories That Can Enhance The Efficiency Of Your Operations!

Specifications

Model	Capacity**	Motor	Voltage V/HZ/PH	Amps	Transmission	Agitator Speeds (RPMs)***	Safety Guard	Timer	Power Bowl Lift
AE-80N4A#	80 Quart Bowl Max 75 lbs of flour Max 132 lbs of dough	3 HP	220/60/3	21	Hybrid Belt + Gear Driven	1st: 132 2nd: 193 3rd: 234 4th: 342	Yes	15 min	Yes

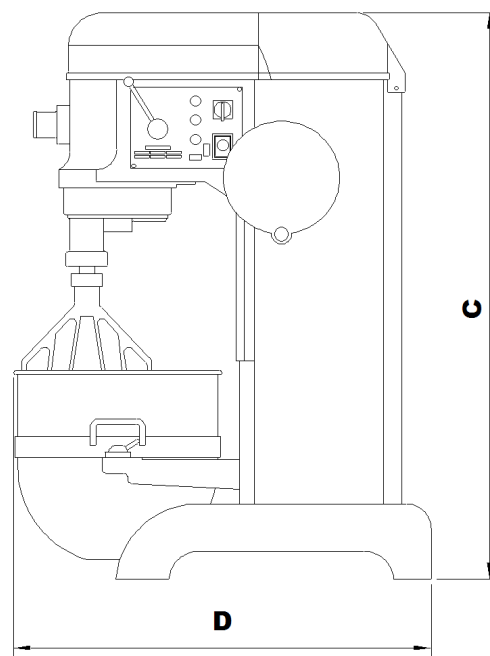
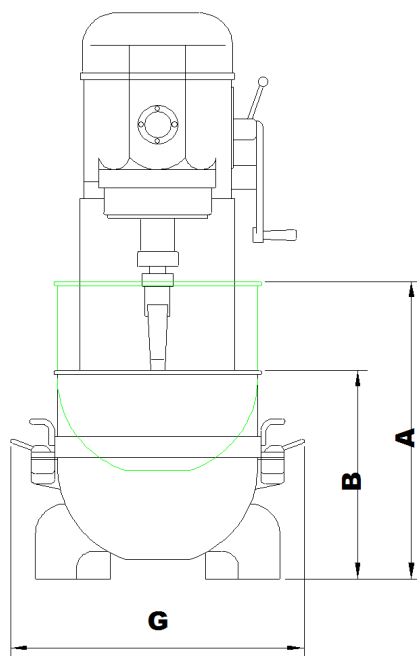

Measurements		
Dimension	US	Metric
A	30.7 in	78 cm
B	22.1 in	56 cm
C	56.7 in	144 cm
D	41.7 in	106 cm
E	33.5 in	85 cm
F	20.1 in	51 cm
G	28.4 in	72 cm

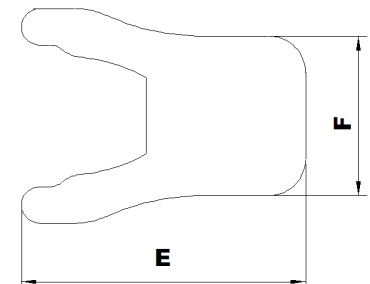

Line drawing is referenced for dimensions, current product may vary due to cosmetic design changes

Dimensions and Shipping Information

Model	Overall Dimensions	Foot Print	Net Weight	Shipping Dimensions****	Ship Weight	Freight Class
AE-80N4A#	28.4" W x 41.7" L x 58" H 72cm x 106cm x 147cm	28" W x 33.5" D 71cm x 85cm	1323 lbs (600 kg)	48" W x 36" L x 68" H 121cm x 90cm x 171cm	1495 lbs (678 kg)	85

*Warranty must be registered. Proper electrical installation required, improper wiring will void warranty. See manual for details. Extended warranty available at extra cost

**Capacity may be diminished depending on dough density and absorption ratio. Rated capacities for typical bread dough. See manual for details

***Use of high speed with heavy dough or overloading machine will void warranty, changing speeds improperly will void warranty. To change speeds, first turn off the machine. Move the lever into position so that the transmission locks, then resume mixing. See manual for details

****Crates are affixed to a skid (pallet). The weight and dimensions of this skid are included above and may vary

#Special Order Item. Please Allow 6-8 Weeks For Manufacturing And Delivery



Quality • Value • Reliability