



Project Name: _____

Location: _____

Item #: _____

Qty: _____

Grista Undercounter Refrigerator, 3 Door - 19 Cu Ft, 72"

GRUCRF-72



The Grista 3 Door Undercounter Refrigerator is designed to maximize storage space while maintaining a sleek, compact footprint in your commercial kitchen. Crafted from heavy-duty stainless steel, this durable unit is built to endure the rigorous demands of a busy commercial kitchen environment. Its flat stainless steel countertop not only provides additional workspace, but also seamlessly integrates into your existing kitchen layout. This unit has three doors with recessed handles and 15.5 cubic feet of storage.

FEATURES AND CONSTRUCTION

- Ideal for adding more storage space anywhere you need it
- Constructed of heavy-duty stainless steel, making it strong and durable enough to survive in any commercial kitchen environment
- 15.5 cu ft (439 L) storage capacity
- 3 doors with recessed door handles let you easily access the contents
- Flat stainless steel countertop can be used as a separate workstation
- Includes 12 plastic coated wire shelves to keep ingredients organized
- (4) 4" casters (2 locking and 2 non-locking) let you easily roll it out for cleaning or maintenance
- Painted aluminum interior
- Environmentally-friendly R290 refrigerant
- Precise digital temperature controller with LED display

ELECTRIC

115V / 60Hz / 1Ph
Cord Length (Inches): 98.40"
Plug Type: NEMA-5-15P
Cord set included

NEMA 5-15P



3RD PARTY APPROVALS

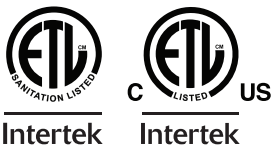

NOMINAL STORAGE CAPACITY

Cubic Feet: 18.9 cu. ft.

TEMPERATURE

Holding Temperature (Fahrenheit): 33° - 40°

These models are designed to operate in an environment where temperature and humidity do not exceed 75°F (24°C) and 55% relative humidity

WARRANTY (USA / CANADA)

2 Year Warranty on Parts & Labor, 5 Years on Compressor
Contact Admiral Craft Equipment for details at 1-877-672-7740





Grista Undercounter Refrigerator, 3 Door - 19 Cu Ft, 72"

GRUCRF-72

FRONT

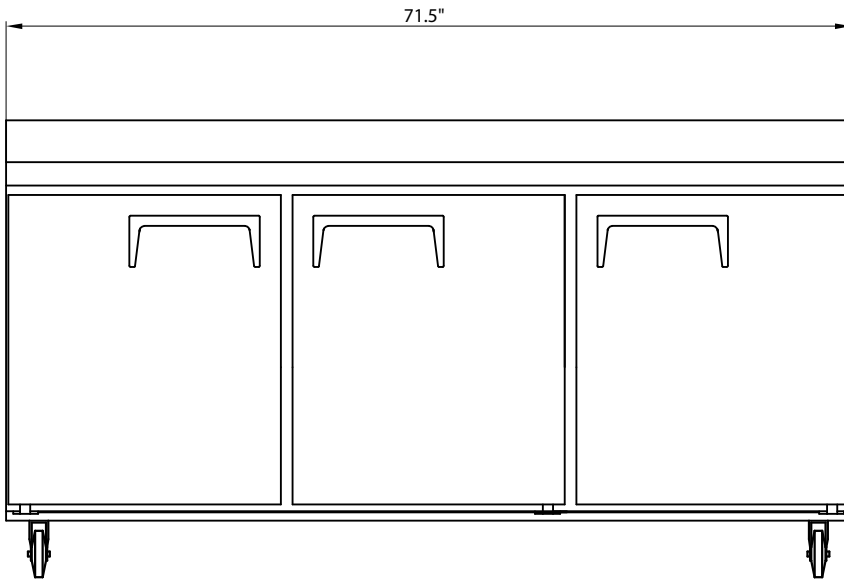

SIDE

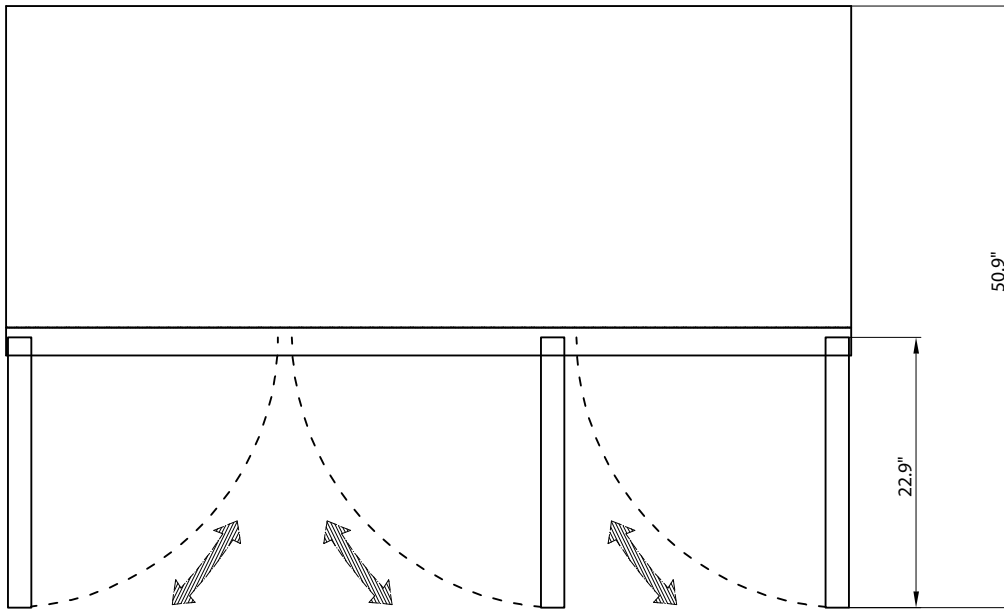
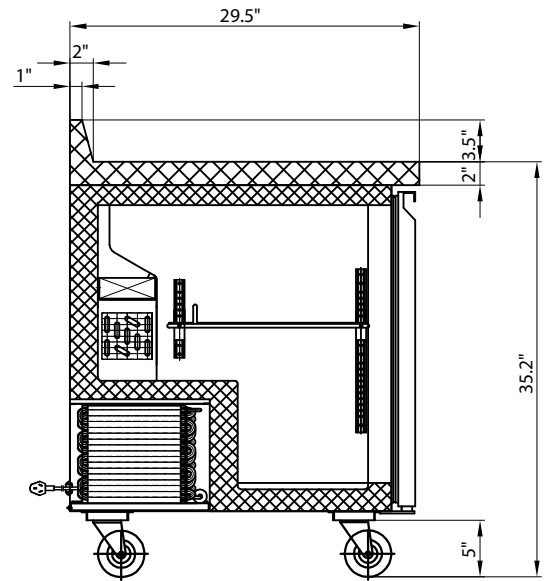

TOP

Undercounter Refrigerators

| Doors | Shelves | Amps | HP | Refrigerant | Dimensions | Item Weight lbs | Shipping Weight lbs |
|-------|---------|------|-----|-------------|-----------------------|-----------------|---------------------|
| 3 | 3 | 2.7A | 0.5 | R290 | 71.5" x 29.5" x 35.2" | 297.0 | 370.0 |

Due to periodic changes in designs, methods, procedures, policies and regulations, the specifications contained in this document are subject to change without notice. While we exercise good faith efforts to provide information that is accurate, we are not responsible for errors or omissions in information provided or conclusions reached as a result of using the specifications. By using the information provided, the user assumes all risks in connection with such use.