



YOU CAN TRUST

## FOOD WARMER DISPLAY CASE

**FWDE2-25 / FWDE2-37**



**FWDE2-25**  
Food Warmer Display Case  
Economy Line



**FWDE2-37**  
Food Warmer Display Case  
Economy Line

### STANDARD FEATURES

Economy Food Warmer Display Cases are beautifully designed yet offer the best value for the money. These units feature curved tempered glass, polished stainless steel construction and tempered glass sliding rear doors.

Thermostatically controlled for consistent temperatures to keep foods hot and fresh.

FWDE2-25 comes standard with 8 stainless steel trays and FWDE2-37 with 12 stainless steel trays.

- Double shelf
- Dry heating
- Curved tempered glass
- Tempered glass sliding rear doors
- Thermostatically controlled to keep food warm and fresh

ILLUSTRATIVE PHOTO, ACTUAL PRODUCTS AND ACCESSORIES ARE SUBJECT TO CHANGE WITHOUT NOTICE



**Skyfood Equipment LLC**  
175 SW 7th Street, Ste 2416  
Miami, FL 33130

**Toll Free:**  
1-800-503-7534  
sales@skyfood.us

[www.skyfood.us](http://www.skyfood.us)



Follow us to keep up to date with the later news and offers

/SkyfoodEquipment

/SkyfoodEquipment

/SkyfoodEquipment



YOU CAN TRUST

# FOOD WARMER DISPLAY CASE

## FWDE2-25 / FWDE2-37



### DIMENSIONS - FWDE2-25

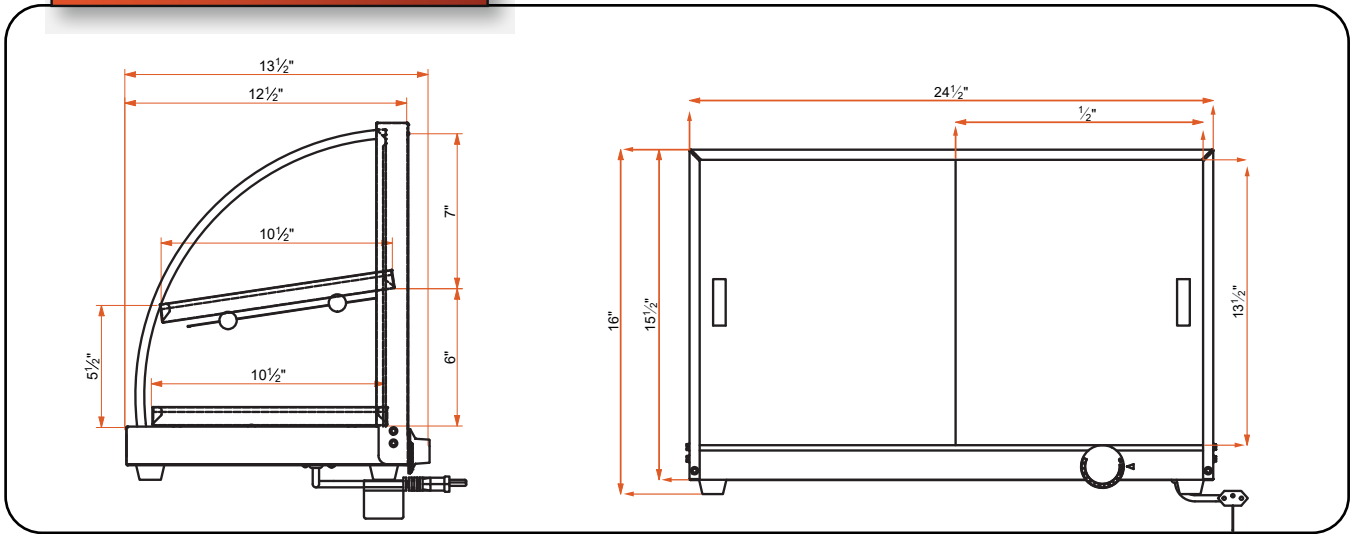

### DIMENSIONS - FWDE2-37

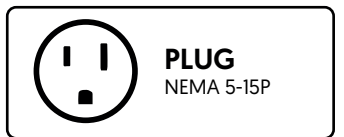
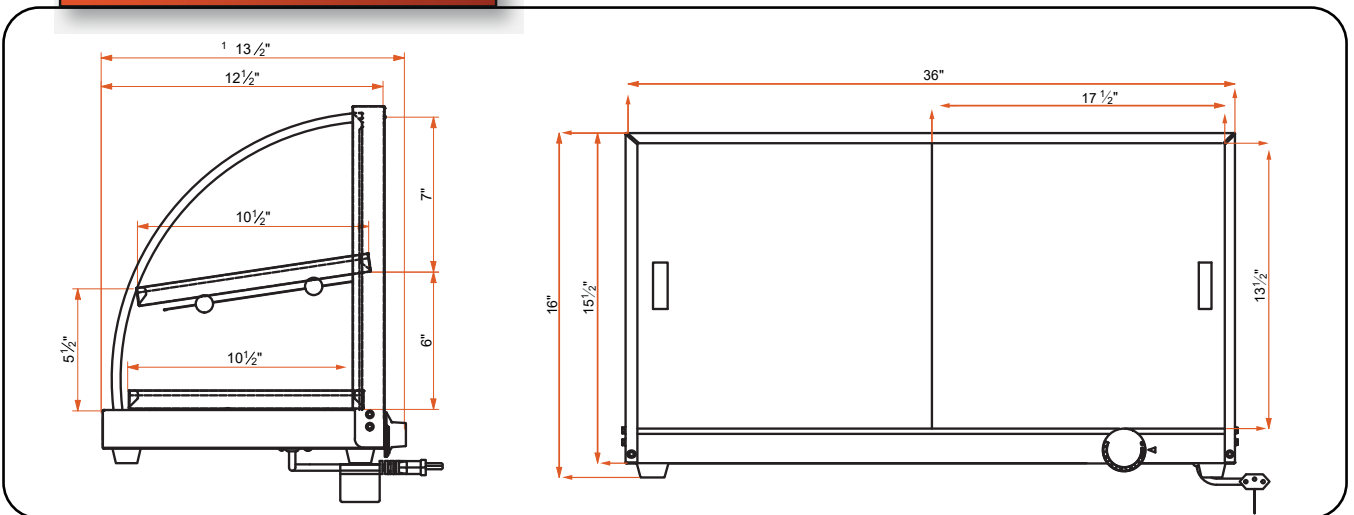

**WARRANTY 01 YEAR PARTS AND LABOR VALID IN THE CONTINENTAL UNITED STATES.**

Item	Voltage	Power Rating	Dimensions (W x D x H)	Weight (Net x Ship)	Tray Dimensions	#of Shelves x #of Trays	Max. Temperature*	Max. Inner Temperature*
FWDE2-25	110 V	500 W	24 3/4" x 13 3/8" x 16 1/8"	27 lb x 31 lb	5 1/2" x 12.5" x 3/4"	2 X 8	248 F	194 F
FWDE2-37	110 V	500 W	36 5/8" x 13 3/8" x 16 1/8"	36 lb x 45 lb	5 1/2" x 12.5" x 3/4"	2 X 12	248 F	194 F



**Skyfood Equipment LLC**  
175 SW 7th Street, Ste 2416  
Miami, FL 33130

**Toll Free:**  
1-800-503-7534  
sales@skyfood.us

[www.skyfood.us](http://www.skyfood.us)



Follow us to keep up to date with the later news and offers

[/SkyfoodEquipment](#)

[/SkyfoodEquipment](#)

[/SkyfoodEquipment](#)

ILLUSTRATIVE PHOTO, ACTUAL PRODUCTS AND ACCESSORIES ARE SUBJECT TO CHANGE WITHOUT NOTICE