



BEVERAGE-AIR

Project: _____	AIA#
Item: _____	
Location: _____	SIS#
Approved: _____	

HBF27HC BOTTOM MOUNT REACH-IN FREEZER

HORIZON BOTTOM MOUNT REACH-IN

HBF27HC Solid Door Reach-In Freezer

Hydrocarbon Series

MODEL:
HBF27HC-1



7 Year Parts/Labor Warranty
7 Year Compressor Warranty

CABINET CONSTRUCTION

- Stainless steel front, side, and grille (galvanized back & bottom)
- Stainless steel interior
- LED lighting
- Full electronic control with one-touch defrost
- One-piece grille allow easy removal/installation for preventative maintenance
- Door lock (solid doors only)
- Self closing door with 120° stay open feature
- Spring-loaded style hinges
- Plug-in magnetic door gaskets
- Three (3) heavy duty epoxy coated wire shelves
- 6" Casters with two (2) brakes

OPTIONS & ACCESSORIES

- Stainless steel universal tray slide pair, 1 tray slide set for (1) 18" x 26" or (2) 14" x 18" pans (AC)
- 3" Casters or 6" legs
- Epoxy shelves
- Shelf clips
- Remote option* (see note on back page)

REFRIGERATION SYSTEM

- Uses environmentally friendly, energy efficient R290 refrigerant, and meets all regulatory requirements for CARB, SNAP, DOE & more
- Hot gas condensate evaporator
- Adaptive defrost
- Epoxy coated evaporator coil
- Freezer capable of maintaining product temperature down to -10°F



Please verify qualifying units by visiting:
www.energystar.gov/cfs

3779 Champion Blvd., Winston-Salem, NC 27105
1-888-845-9800 Fax: 1-336-245-6453
Beverage-Air.com Sales@bevair.com



BEVERAGE-AIR

MODEL	HBF27HC-1
EXTERNAL DIMENSIONAL DATA	
Width Overall	30"
Depth Overall with Handle	33 ³ / ₄ "
Height Overall with Casters	84 ¹ / ₈ "
Number of Doors	1
Depth with Door Open 90°	60 ¹ / ₈ "
Door Opening (in)	26 ⁷ / ₈ " x 52 ³ / ₄ "
INTERNAL DIMENSIONAL DATA	
NET Capacity (cubic ft.)	25.97
Internal Width Overall (in)	27"
Internal Depth Overall (in)	28 ¹ / ₂ "
Internal Height Overall (in)	61 ³ / ₄ "
Internal Height Useable (in)	55"
Number of Shelves	3
ELECTRICAL DATA	
Full Load Amperes	10
Voltage	115/60/1
Nema Plug (8' cord)	5-15P
REFRIGERATION DATA	
Horsepower	3/4
Capacity (BTU/Hr)	2772
Heat Rejection (BTU/Hr)	4158
Charge (lbs/grams/ounces)	0.2204 / 100 / 3.53
SHIPPING DATA	
Gross Weight - Crated	516 lbs
Height - Crated	85"
Width - Crated	33"
Depth - Crated	37"

*NOTE: Remote units are field wired and come with 6" legs.
Refrigerant must be specified at time of order.

We reserve the right to change specifications and product design without notice. Such revisions do not entitle the buyer to corresponding changes, improvements, additions or replacements for previously purchased equipment. Dimensional tolerances +/- 1/4". Metric dimensions (MM).

Bottom Mount Reach-In Freezer Model: HBF27HC-1

Model Views

Required Clearance: Bottom & Rear 3"

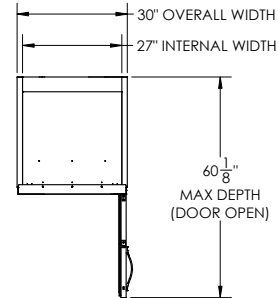

PLAN VIEW

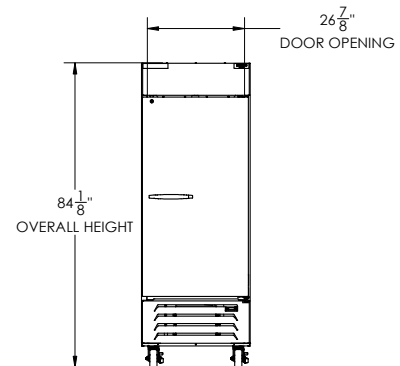

ELEVATION VIEW

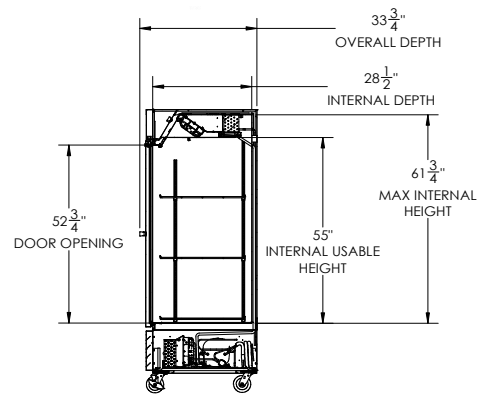

SIDE VIEW

ELECTRICAL CONNECTION



115/60/1
NEMA 5-15P

Unit pre-wired at factory
and include 8' long cord
and plug set.

