



/// Serve perfectly toasted muffins and croissants for breakfast menu items with the RTDL Radiant Toaster with Dual Lanes from Antunes.

The Radiant Toaster with Dual Lanes features two toasting lanes for a high toasting capacity while maximizing valuable counterspace. Designed for quality and consistency, the RTDL uses a smart controller that senses product and automatically adjusts toasting time for the perfect caramelized crispiness, every time, for every volume.

Each toasting lane is independently controlled for maximum flexibility while toasting different products at once. The RTDL's front load and front return allows operators to work quickly and efficiently without wasting any time or energy reaching for product. With an integrated holding zone, operators can keep up with demand during peak hours.

FEATURES:

- /// Dual toasting lanes with independent controls for toasting a variety of products, including muffins and croissants.
- /// Smart controller senses product and automatically adjusts toast time.
- /// Independent, adjustable top and bottom heaters.
- /// Programmable touchpad controller.
- /// Removable crumb tray for easy cleaning.
- /// Front load and front return.
- /// Compact footprint.
- /// Integrated landing zone.



RTDL



/// Radiant Toaster with Dual Lanes | RTDL

Dimensions

Model & Mfg. No.	Width (A)	Depth (B)	Height (C)
RTDL 9210927	14" (356 mm)	19" (481 mm)	23 1/2" (597 mm)
With Heat Shield and Feeder Attached			
RTDL 9210927	14" (356 mm)	23" (584 mm)	24" (610 mm)

Shipping Dimensions

Model & Mfg. No.	Width	Depth	Height	Weight
RTDL 9210927	23" (584 mm)	18" (457 mm)	30" (762 mm)	90 lbs. (40.8 kg)

Single units ship via parcel.

Electrical Ratings

Model & Mfg. No.	Volts	Phase	Watts	Amps	Hertz	Plug Description
RTDL 9210927	208	1	5000	24	50/60	NEMA L6-30P 250 Volt, 30 Amp, Twist Lock

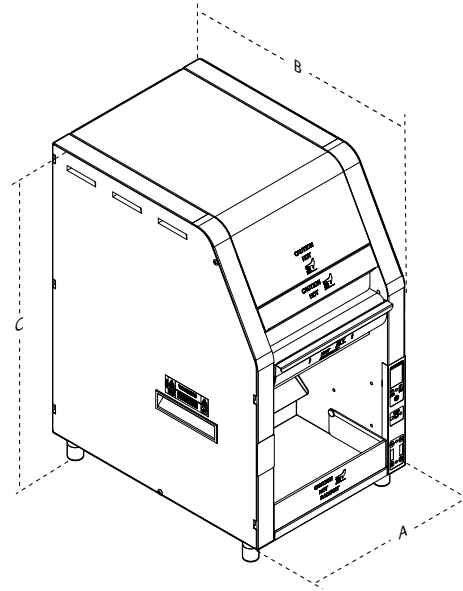

Accessories

- /// Temperature Control: Solid State with Display
- /// Power Cord: Six-foot grounded power cord supplied



Antunes delivers a complete range of countertop cooking equipment and water filtration solutions to foodservice operations around the world. Learn more about Antunes and its products at antunes.com.

UNITED STATES CORPORATE HEADQUARTERS

Carol Stream, Illinois, USA
Phone: +1.630.784.1000
Toll Free: +1.800.253.2991

UNITED STATES INNOVATION CENTER

Crystal Lake, Illinois, USA
Phone: +1.630.784.1000
Toll Free: +1.800.253.2991

CHINA FACILITY

Suzhou, China
Phone: +84.512.6841.3637
Fax: +86.512.6841.3907

INDIA FACILITY

Chennai, India
Phone: +91.44.25532212
Fax: +91.44.25532415