



## Features

### **Eco-Friendly Refrigerant**

R290 refrigerant with a global warming potential (GWP) of 3

### **Quick-Load Milk Crates**

Loading product is simple with the auto-align connector slot that ensures correct positioning — an additional platform accessory is available to accommodate bag-in-box

### **Minimal Waste**

Angled milk crate design pushes product toward the dispense point to maximize yield

### **Made to Last**

Stainless steel exterior with galvanized bottom reduces the risk of corrosion

### **Long-Lasting, Removable Gaskets**

Santoprene™ gaskets last four times longer than standard gaskets

### **High-Density Insulation**

Foamed-in-place, CFC-free polyurethane insulation provides maximum strength, rigidity, and insulation

### **High-Capacity**

Each milk crate can hold a 3-gallon, 5-gallon, or 6-gallon bag — also accommodates a bag-in-box and manual-fill stainless steel can

### **Single Valve Dripless Dispense**

Spring-loaded lift valve ensures dripless dispense for optimal sanitation, reduced waste, and convenient one-handed operation

### **Easy to Clean**

The stainless steel interior with coved corners, finished edges, removable door gasket, and elevated legs make cleaning simple

### **Heavy-Duty, Locking Door**

High-strength door with heavy-duty hinges ensure lasting performance — latch can accommodate locks and security tags

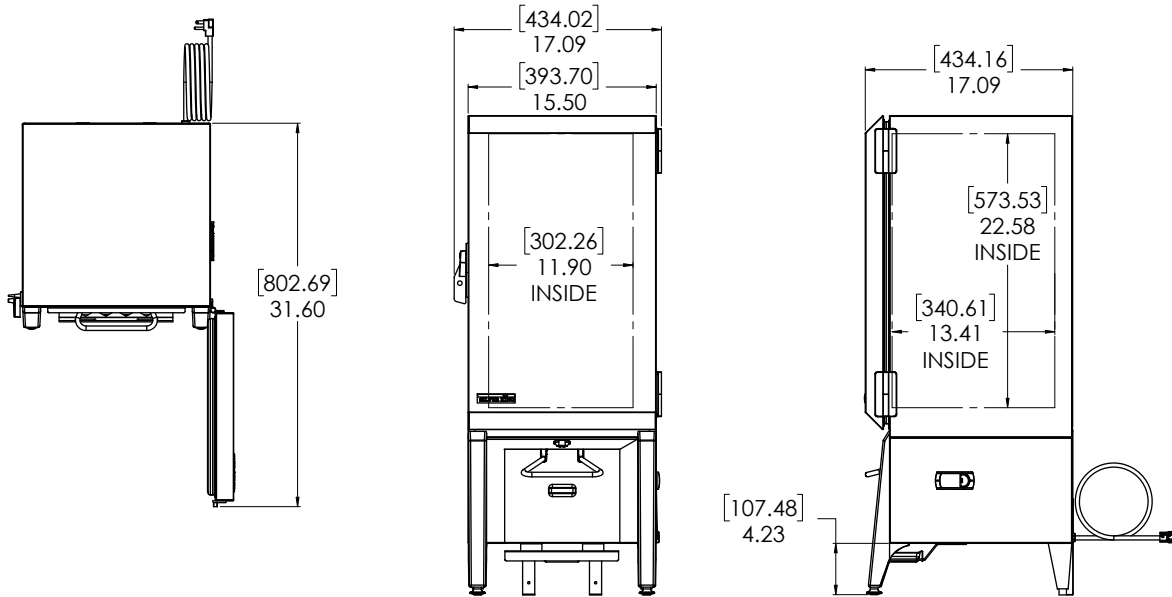

## Technical Specifications

<b>Electrical Requirements</b>	115v/60hz/1ph/1.6A/NEMA 5-15P Plug
<b>Product Dimensions</b>	17.09"W x 17.09"H x 39.48"D (43.41cm x 43.41cm x 100.28cm)
<b>Product Weight</b>	110lbs (49.90kg)
<b>Shipping Dimensions</b>	25"W x 26"H x 48"D (63.50cm x 66.04cm x 121.92cm)
<b>Shipping Weight</b>	120lbs (54.43kg)
<b>Shipping Cubic Dimensions</b>	18.06ft <sup>3</sup> (0.51Cu.M)
<b>Temperature Range</b>	38 to 40°F (3.3 to 4.4°C)
<b>Refrigerant</b>	R290
<b>Insulation</b>	Foamed-in-place, CFC-free polyurethane

<b>Exterior Construction</b>	Stainless steel exterior with galvanized bottom
<b>Interior Construction</b>	Stainless steel interior with coved corners and finished edges
<b>Doors</b>	One (1) right-hand swing with lockable latch
<b>Valves</b>	One (1) spring-loaded lift valve
<b>Crates</b>	One (1) milk crate (accommodates 3-gallon, 5-gallon, or 6-gallon bags)
<b>Internal Capacity</b>	6-Gallons
<b>Door Gasket</b>	Long-lasting, removeable Santoprene™ gasket
<b>Legs</b>	Adjustable standard legs or adjustable shipboard legs
<b>Certifications</b>	ETL SAFETY, ETL SANITATION NSF 7
<b>Warranty</b>	1-year parts and labor, 5-year compressor (part only)

Model Number	Description
SKMAJ1-ESUS3	Majestic Milk Dispenser, 115v/60hz/1ph/1.6A, 1 valve, (1) 6-gallon crates, shipboard legs, NEMA 5-15P
SKMAJ1-ESUS4	Majestic Milk Dispenser, 115v/60hz/1ph/1.6A, 1 valve, (1) 6-gallon crates, adjustable legs, NEMA 5-15P

Accessories	Description
35904	Milk Crate for 3-Gallon, 5-Gallon, or 6-Gallon Bags
62642	3-Gallon Milk Can
60224	5-Gallon Milk Can
63959	Platform Adaptor for Bag-in-Box
20323	Milk Tubes
10314-96	Shipboard Legs

To learn more about **Silver King Milk Dispenser**, visit [silverking.com](http://silverking.com)