

# AMERICAN RANGE

Chef Inspired, Professional Cooking Equipment

## Culinary Series SERIES WOK RANGES

### STANDARD FEATURES

- Stainless Steel front and sides.
- Heavy gauge steel with welded-in 2" high 13" or 16" wok opening.
- Heavy gauge steel chassis.
- 20 tip **Power-Plus** 100,000 BTU/hr. jet burner.
- Brass control valve with large width aluminum handle.
- Adjustable bullet feet for leveling.
- 13" or 16" diameter wok rings.

### OPTIONAL FEATURES

- **Power-Plus** 90,000 BTU/hr. Burners
- Tempura style with 3 - ring burner (90,000 BTU.)
- 13" (330) or 16" (406) diameter wok rings, others available call factory.
- Water wash style with various sized openings, call for details and pricing.
- Swivel casters.



GAS TYPE:  NATURAL  LP



**Model ARWR-J13**

**Power-Plus**

100,000 BTU/hr. Jet Burner

**Model ARWR-3R**

**Power-Plus**

90,000 BTU/hr. 3-Ring Burners

The **Culinary Series** Range by American Range, ARWR Series of Wok Ranges are design engineered to provide years of dependable service. Heavy gauge construction and Stainless Steel sides and front provide durability and easy cleaning. The top is heavy gauge steel with welded on stubs to firmly hold the wok. A large aluminum leverhandle for the gas valve facilitates "knee control" allowing hands-free cooking. The standard 20 tip jet burner gives **Power-Plus** 100,000 BTU/hr. heat capacity, with a Stainless Steel standing pilot for instant ignition.

Look to American Range for innovation, reliable performance, quality and attention to your equipment needs and prompt delivery, now and for all your future needs.

Quality, dependability and customer satisfaction make American Range the **brand of choice among professional chefs and restaurateurs worldwide.**

# Culinary Series

## SERIES WOK RANGES

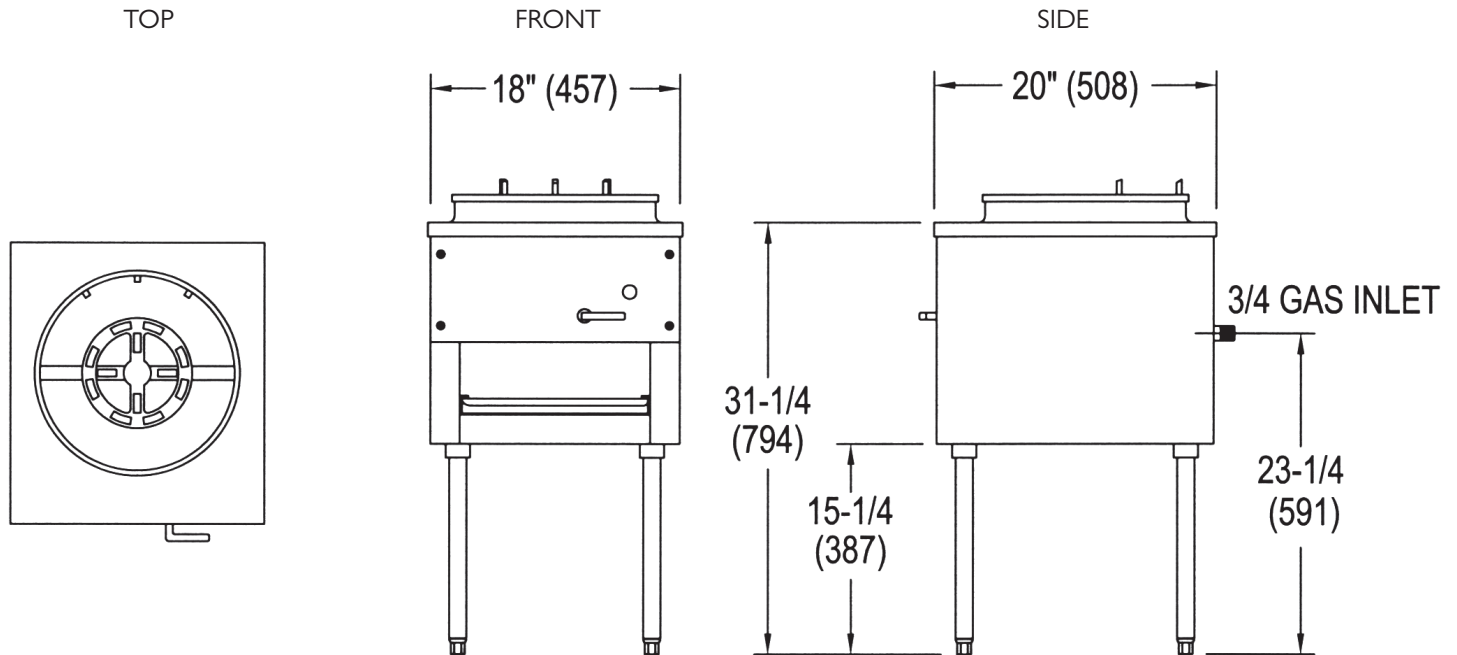

Model	Width	Depth	Height	Burners	Total BTU	KW	Shipping Weight	Lbs.	Kg.
ARWR-3R	18"	20"	32-1/2"	3 - ring	90,000	26		130	58
ARWR-J13	18"	20"	32-1/2"	20 tip jet	100,000	29.3		120	50
ARWR-J16	18"	20"	32-1/2"	20 tip jet	100,000	29.3		120	50

### STANDARD FEATURES

- Stainless Steel front and sides.
- Heavy gauge steel with welded-in 2" high 13" wok opening.
- Heavy gauge steel chassis.
- 20 tip **Power-Plus** 100,000 BTU/hr. jet burner.
- Brass control valve with large width aluminum handle.
- Adjustable bullet feet for leveling.
- 13" or 16" diameter wok rings.
- Optional swivel casters available.
- One year limited warranty, parts and labor.
- **Power-Plus** 90,000 BTU/hr. Burners

### OPTIONAL FEATURES

- Tempura style with 3 - ring burner (**Power-Plus** 90,000 BTU.)
- 13" (330) or 16" (406) diameter wok rings, others available, call factory.
- Water wash style with various sized openings, call for details and pricing.
- Swivel casters.
- Non clogging duck-tip jet burner available.

### GAS SUPPLY:

3/4" NPT Gas inlet. Manifold pressure is 5.0"W.C. for natural gas or 10.0"W.C. for propane gas. Specify type of gas and altitude if over 2000 feet.

### CLEARANCES:

For use only on non-combustible floors. Legs or casters are required, or 2" (51) overhang is required when curb mounted. **For use on non-combustible floors. Legs or casters are required.** Clearance from non-combustible walls is 0". When unit is placed next to combustible walls, clearances must exceed 12" (305) on sides, and 4" (102) from rear. Radiant broilers for non-combustible locations only.

American Range is a quality manufacturer of commercial cooking equipment. Because of continuing product improvements these specifications are subject to change without prior notice.



A70178  
07162021 Rev. B

**AMERICAN RANGE**  
Chef Inspired, Professional Cooking Equipment

13592 Desmond St. Pacoima CA 91331  
T. 818.897.0808 F. 818.897.1670  
Toll Free: 888.753.9898  
www.americanrange.com