



DIRECT STEAM KETTLES ON CABINET BASE

DMT-10-10

OPERATION SHALL BE BY:

Direct steam at a minimum of 5 psi (34 kPa) and a maximum of 45 psi (310 kPa) 1/4 BHP required.

Standard Features

- Type 316 stainless steel liner
- Steam control valve

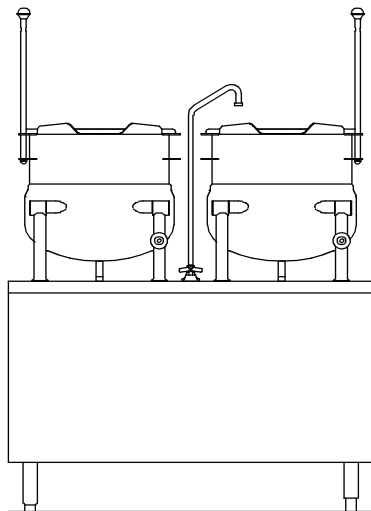

OPTIONS & ACCESSORIES AT ADDITIONAL COST

- | | | |
|--|--|---|
| <input type="checkbox"/> Etched gallon markings (GM-) | <input type="checkbox"/> Stainless steel back panel (SSB-42) | <input type="checkbox"/> Contoured measuring strip (CMS-) |
| <input type="checkbox"/> Etched litre markings (LM-) | <input type="checkbox"/> Stainless steel frame (SSF-42) | <input type="checkbox"/> Ball float trap (BFT) |
| <input type="checkbox"/> Correctional package | <input type="checkbox"/> One piece stainless steel lift off cover (C-) | <input type="checkbox"/> Pour lip strainer (TKS-) |
| <input type="checkbox"/> Pressure reducing valve (PRV-2) | <input type="checkbox"/> Lift-out perforated stainless steel basket (SSB-) | |

STANDARD CONSTRUCTION SPECIFICATIONS

Shall be a Crown model DMT-10-10, consisting of two direct connected steam tilting kettles mounted on a cabinet base of modular design to match other CROWN cooking equipment.

Each kettle shall be ASME code stamped and National Board registered.

A double wall kettle interior shall form a steam jacket around the lower 2/3 of the kettle.

The bottom of the kettle shall be of hemispherical design for superior heat circulation.

The liner shall be of 316 stainless steel for high acid content products.

The stainless steel mounting legs shall allow the kettle to be tilted forward past 90° for complete emptying and conceal the steam

supply and condensate return connections, the right leg shall be fitted with a steam control valve.

Each kettle shall be fitted with a tilt handle and heat resistant knob.

The cabinet shall be constructed with full perimeter painted angle frame, reinforced counter, #4 finish stainless steel exterior with removable side panels and hinged doors with magnetic latches, mounted on 6" (152 mm) stainless steel legs fitted with 4 adjustable flanged feet for securing to the floor, a hot and cold water faucet with control valves, 3" (76 mm) deep sinks with drain and splash guard.

Concealed plumbing within the cabinet shall include a steam supply manifold with safety relief valve and a condensate return manifold and a steam trap for each kettle.



Approval Notes: _____

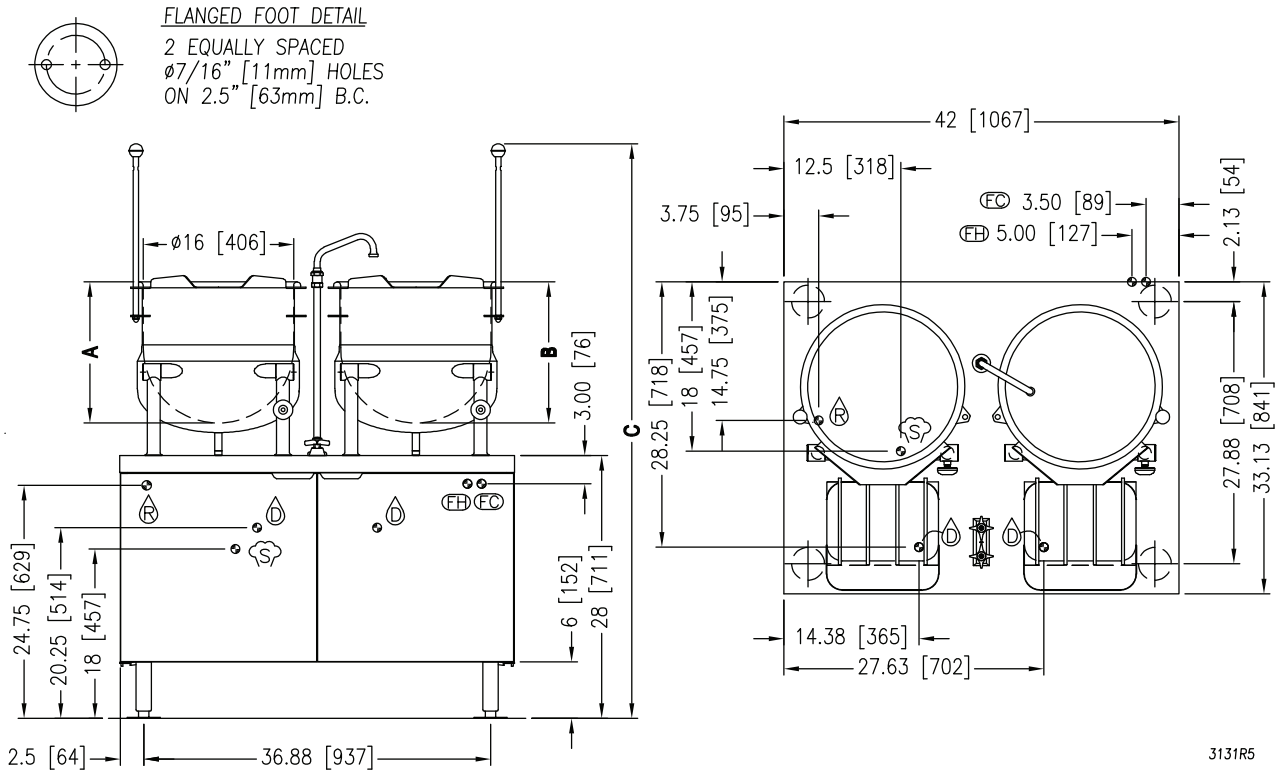

NOTE: SPLASH GUARD NOT SHOWN IN FRONT VIEW.

IN [MM]

SERVICE CONNECTIONS

- STEAM SUPPLY: 3/4" (19 mm) IPS for incoming steam at 5-45 PSI (34-310 kPa).*
- CONDENSATE RETURN: 1/2" (13 mm)
- FAUCET COLD WATER: 3/8" (10 mm) O.D. tubing at 25-50 PSI (170-345 kPa), NSF-61 compliant.
- FAUCET HOT WATER: 3/8" (10 mm) O.D. tubing at 25-50 PSI (170-345 kPa), NSF-61 compliant.
- SINK DRAIN: 1-1/8" (29 mm) O.D. tubing.

* Pressure reducing valve is required if incoming pressure exceeds 50 PSI (345 kPa).

DIMENSIONS AND SPECIFICATIONS

MODEL	A	B	SHIPPING WEIGHT	MINIMUM CLEARANCE	MODEL	CAPACITY
DMT-10-10	15 [381 mm]	33.2 [843 mm]	390 lbs. [177 kg.]	SIDES 0 [0 mm] BACK 0 [0 mm]	DMT-10-10	(2) 10 gallon (38 litre)

DISCLAIMER

Terry System Cartridge Changes / Installation – "2-3 gallons of water MUST be purged at each cartridge change or new installation prior to water supply being fed to the steamer. Failure to do so can result in component damage within the steamer which is not covered under warranty. For additional guidance on proper installation, refer to install documentation provided with each Terry System and Replacement Cartridge Set."

**INTENDED FOR COMMERCIAL USE ONLY.
 NOT FOR HOUSEHOLD USE.**

