



STANDARD FEATURES

Maximize your time and diversify your recipes with this powerful blender.

Supreme Blender is an essential tool in any commercial kitchens, bars, ice cream parlors, smoothie shops, and others.

From preparing milkshakes to pureeing tough fruits and vegetables, our Supreme Blender can handle the pressure of the most demanding commercial kitchens.

- Exclusive powerful 3 peak HP motor that can reach a speed up to 38000 rpm.
- High, Med and Low speed settings and pulse switch
- 3 pre-set one-touch auto timers (35, 60 and 90 seconds)
- Can be used for wet and dry, cold and hot applications
- 68 oz. (2 liters) capacity
- BPA Free - contains no chemical Bisphenol-A
- Tritan plastic container is impact-resistant
- Tapered design container quickly creates a vortex and pulls ingredients into the blades for maximum blending
- Comes standard with lid and tamper
- Automatic overload protection mechanism
- Conforms to the following standards:
UL electrical and sanitation
(under UL, CSA and NSF standards)



BS2
Supreme Blender

ILLUSTRATIVE PHOTO, ACTUAL PRODUCTS AND ACCESSORIES ARE SUBJECT TO CHANGE WITHOUT NOTICE.



Skyfood Equipment LLC
175 SW 7th Street, Ste 2416
Miami, FL 33130

Toll Free:
1-800-503-7534
sales@skyfood.us

www.skyfood.us

 AutoQuotes

 beedash





YOU CAN TRUST

HIGH SPEED BLENDERS

BS2



DIMENSIONS

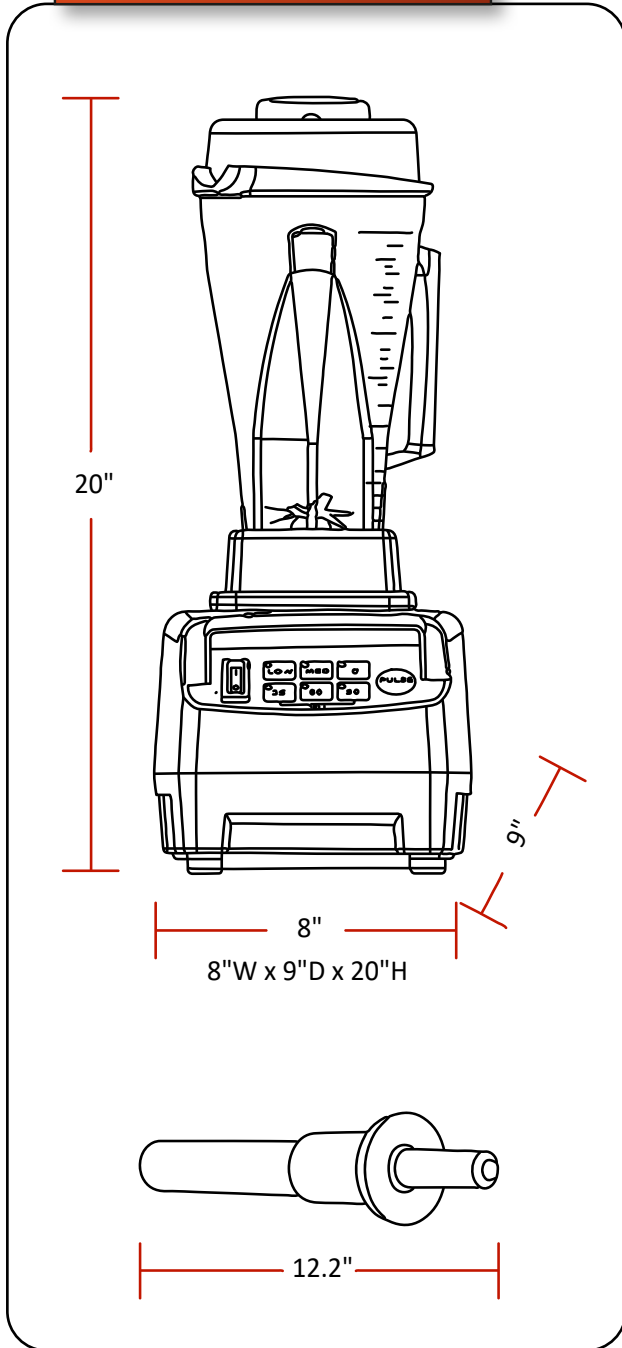

TRITAN CUP™

Innovative material that combines the best characteristics of glass and plastic. Ultra-resistant, free of Bisphenol A, does not release taste or smell and can be used with hot foods or cold drinks.



CCTB2
(Sold separately)

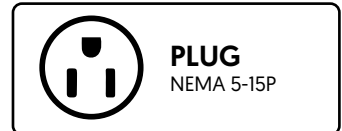
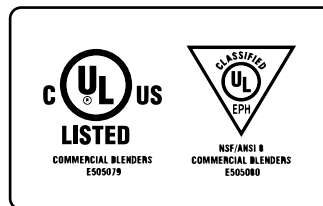

WARRANTY 02 YEARS PARTS AND LABOR VALID IN THE CONTINENTAL UNITED STATES.

| Item | Electrical | Power Rating | Dimensions (W x D x H) | Shipping Dimensions (W x D x H) | Weight (Net x Ship) | Capacity | RPM | PLUG |
|------|--------------|----------------|------------------------|---------------------------------|---------------------|-------------------|-------|------------|
| BS2 | 115V/50-60Hz | 3 peak HP/1050 | 8" x 9" x 20" | 13.6" x 19.5" x 23" | 12 lb x 14.5 lb | 68 oz. (2 liters) | 38000 | NEMA 5-15P |



Skyfood Equipment LLC
175 SW 7th Street, Ste 2416
Miami, FL 33130

Toll Free:
1-800-503-7534
sales@skyfood.us

www.skyfood.us



Follow us to keep up to date with the latest news and offers

[/SkyfoodEquipment](#) [/SkyfoodEquipment](#) [/SkyfoodEquipment](#)

ILLUSTRATIVE PHOTO, ACTUAL PRODUCTS AND ACCESSORIES ARE SUBJECT TO CHANGE WITHOUT NOTICE