



XAF STATIONS

MODEL: XAFS-133-2

The XAF Station is a heavy duty, manual control oven featuring two XAF convection ovens, stacked on the OST Cadco stand, offering enhanced capacity and efficient cooking.

It's compact and easy-to-manage and perfect for establishments requiring high-volume cooking with minimal space.

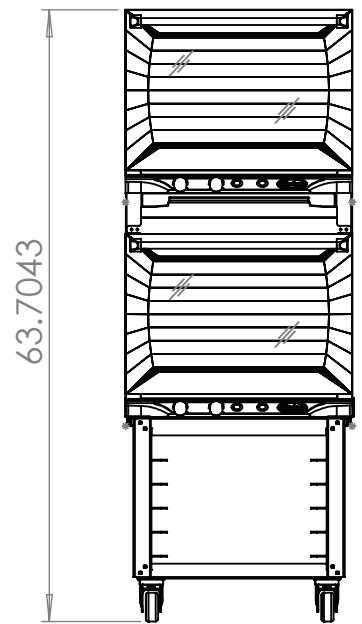
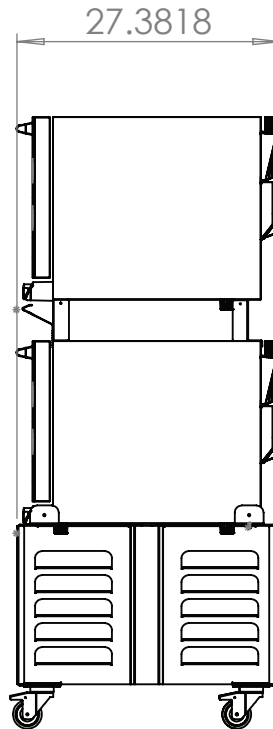
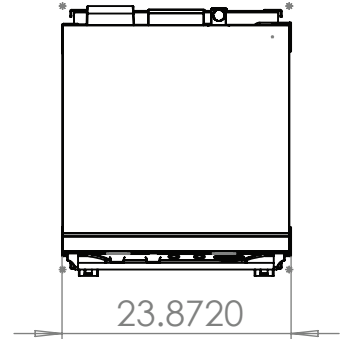
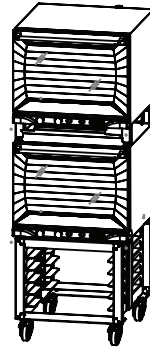

SPEC FOR EACH XAF-133

Unit Dimensions (W" x H" x D"): 23 5/8 x 20 x 28 1/8
Cavity Size (W" x H" x D"): 19 1/2 x 13 x 15 1/2; 2.27 cft.
(One fan. NEMA 6-20P plug)
Shelves: 4 Volts: 208-240 Watts: 2700 Amps: 20

SPEC FOR CXC 651 (Stacking Kit)

Stacking Kit (for Half Size XAF Manual Ovens)
Stainless front piece with integral columns, heat baffle
Stainless back piece with integral columns
Screws, Bottom oven vent extension & clamp
90 day warranty

SPEC FOR OST-34A-CS

Handles 5 full size sheet pans (not included)
Aluminum (assembly required)
Silent casters (2 with brakes, 2 with directional locks)
Unit: 23.87" W x 23" H x 27" D

XAFS-133-2 will ship as two pallets. Pallet #1: 38x35x56 (250lbs) Pallet #2: 38x35x28 (190lbs)



www.cadco-ltd.com



860.738.2500



info@cadco-ltd.com