



Project Name: \_\_\_\_\_

Location: \_\_\_\_\_

Item #: \_\_\_\_\_

Qty: \_\_\_\_\_

# Grista Mega Top Sandwich/Salad Prep Table, 2 Door - 60"

## GRSLM-2D/60



Streamline the preparation of sandwiches and salads in your commercial kitchen with the Grista 2 Door Refrigerated Mega Top Salad/Sandwich Prep Table. Combining refrigerated storage with a convenient workspace, it offers more storage and preparation space than a standard salad and sandwich prep table. Ideal for any deli, sandwich shop, restaurant or cafe, this mega prep table will help optimize your foodservice operations. The stainless-steel two-door prep station has a cold topping area.

### FEATURES AND CONSTRUCTION

- Store all of your condiments, meats and vegetables in the cold topping area that can hold a variety of different sized food pans up to 6" deep
- Durable 430 series stainless steel exterior, painted aluminum interior and two doors with recessed handles
- One plastic coated wire shelf per section/door
- Equipped with a 3/4" thick removable polyethylene cutting board that provides a convenient space for assembling sandwiches and salads
- Store additional food items below in the cabinet for quick access when needed
- Oversized hinged insulated cover keeps food items cold when not in service
- 15 cu ft storage capacity
- Precise digital temperature controller with LED display
- Temperature range of 33°F to 41°F (1°C to 5°C)
- (4) 4" casters (2 locking and 2 non-locking) for easy mobility in your commercial kitchen

### ELECTRIC

115V / 60Hz / 1Ph  
Cord Length (Inches): 98.40"  
Plug Type: NEMA-5-15P  
Cord set included

NEMA 5-15P



### 3RD PARTY APPROVALS

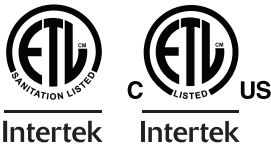

### WARRANTY (USA / CANADA)

2 Year Warranty on Parts & Labor, 5 Years on Compressor  
Contact Admiral Craft Equipment for details at 1-877-672-7740



### NOMINAL STORAGE CAPACITY

Cubic Feet: 18.4 cu. ft.

### TEMPERATURE

Holding Temperature (Fahrenheit): 33° - 40°

These models are designed to operate in an environment where temperature and humidity do not exceed 75°F (24°C) and 55% relative humidity



# Grista Mega Top Sandwich/Salad Prep Table, 2 Door - 60"

GRSLM-2D/60

FRONT

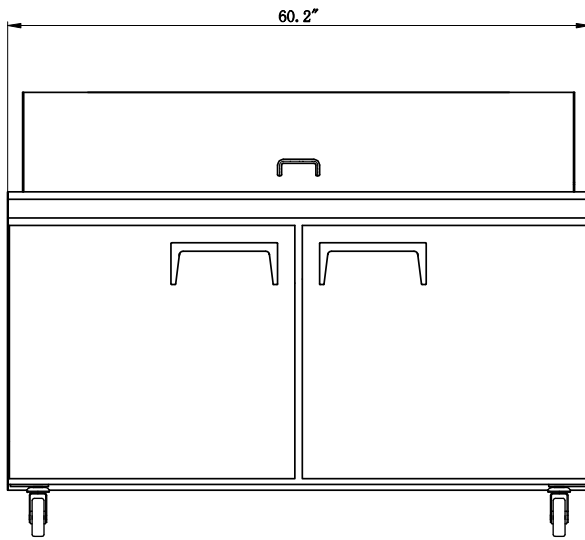

ELEVATION

SIDE

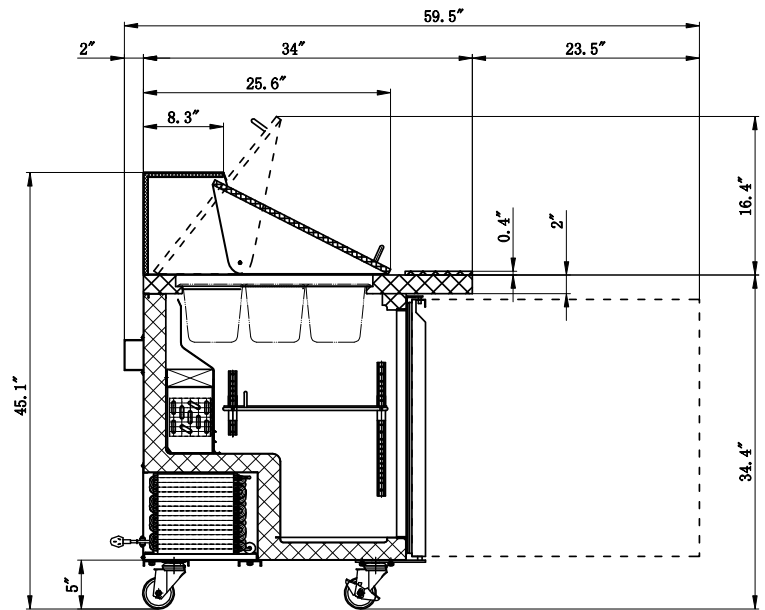

SECTION VIEW

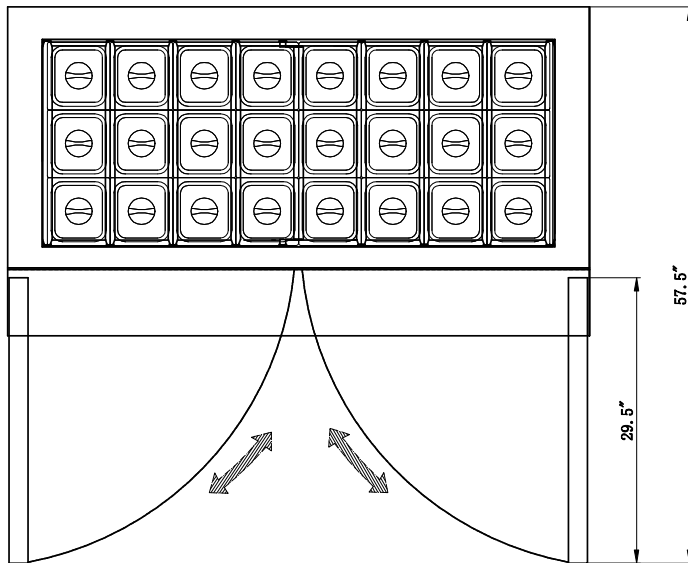

PLAN

TOP

## Mega Top Prep Tables

Doors	Shelves	Amps	HP	Refrigerant	Capacity	Dimensions	Item Weight lbs	Shipping Weight lbs
2	2	5.4A	0.75	R290	18.4 cu. ft.	60.2" x 34" x 45.9"	341.0	427.0

Due to periodic changes in designs, methods, procedures, policies and regulations, the specifications contained in this document are subject to change without notice. While we exercise good faith efforts to provide information that is accurate, we are not responsible for errors or omissions in information provided or conclusions reached as a result of using the specifications. By using the information provided, the user assumes all risks in connection with such use.