



# BEVERAGE-AIR

Project: _____	AIA#
Item: _____	
Location: _____	SIS#
Approved: _____	

**FB72HC BOTTOM MOUNT: VISTA® SERIES**

## VISTA® BOTTOM MOUNT REACH-IN FREEZER

FB72HC Glass Door Reach-In Freezer  
Hydrocarbon Series

MODEL:  
FB72HC-1G



**7 Year Parts/Labor Warranty  
7 Year Compressor Warranty**

### CABINET CONSTRUCTION

- Stainless steel front and grille, gray painted sides
- Gray painted aluminum interior
- Full electronic control
- LED lighting
- Self-closing doors with 120° stay-open feature, on spring-loaded hinges
- One-piece grille allow easy removal/installation for preventative maintenance
- Nine (9) heavy duty epoxy coated wire shelves standard
- 6" Casters standard with (2) brakes

### OPTIONS & ACCESSORIES

- Stainless steel universal tray slide (AC)
- Additional epoxy shelves
- Shelf clips
- 3" Casters or 6" legs
- 6" Flanged/seismic feet
- Door locks
- Remote option\* (see note on back page)

### REFRIGERATION SYSTEM

- Uses environmentally friendly, energy efficient R290 refrigerant, and meets all regulatory requirements for CARB, SNAP, DOE & more
- Hot gas condensate evaporator
- Adaptive defrost
- Epoxy coated evaporator coil
- Maintains product temperatures of 0° F and below



 Please verify qualifying units by visiting:  
[www.energystar.gov/cfs](http://www.energystar.gov/cfs)

3779 Champion Blvd., Winston-Salem, NC 27105  
1-888-845-9800 Fax: 1-336-245-6453  
Beverage-Air.com Sales@bevair.com



# BEVERAGE-AIR

## VISTA® Bottom Mount Reach-In Freezer Model: FB72HC-1G

MODEL	FB72HC-1G
<b>EXTERNAL DIMENSIONAL DATA</b>	
Width Overall	75"
Depth Overall with Handle	33 1/2"
Height Overall	84 1/8"
Number of Doors	3
Depth with Door Open 90°	55 1/8"
Door Openings (in)	21 7/8" x 52 3/4"
<b>INTERNAL DIMENSIONAL DATA</b>	
NET Capacity (cubic ft.)	68.43
Internal Width Overall (in)	72"
Internal Depth Overall (in)	28 1/2"
Internal Height Overall (in)	61 3/4"
Internal Height Useable (in)	55"
Number of Shelves	9
<b>ELECTRICAL DATA</b>	
Full Load Amperes	15.93
Voltage	115/60/1
Nema Plug (8' cord)	5-20P
<b>REFRIGERATION DATA</b>	
Horsepower	(2) 3/4
Capacity (BTU/Hr)	(2) 2450
Heat Rejection (BTU/Hr)	7350
Charge (lbs/grams/ounce)	(2) .2204 / 100 / 3.5
<b>SHIPPING DATA</b>	
Gross Weight (crated lbs)	748 lbs
Height - Crated	84"
Width - Crated	78"
Depth - Crated	36"

\*NOTE: Remote units are field wired and come with 6" legs.  
Refrigerant must be specified at time of order.

We reserve the right to change specifications and product design without notice. Such revisions do not entitle the buyer to corresponding changes, improvements, additions or replacements for previously purchased equipment. Dimensional tolerances +/- 1/4". Metric dimensions (MM).

### Model Views

Required Clearance: Rear 3" & Bottom 3"

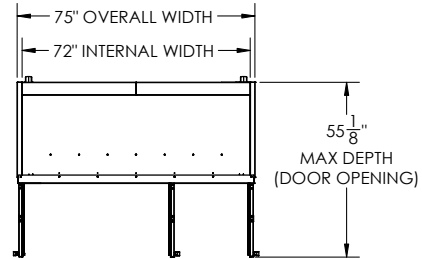

### PLAN VIEW

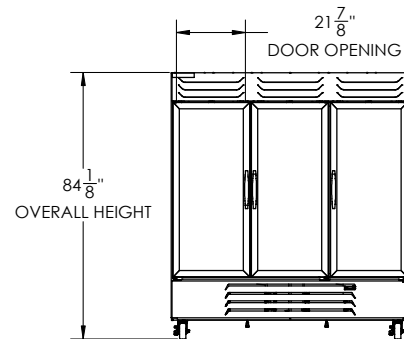

### ELEVATION VIEW

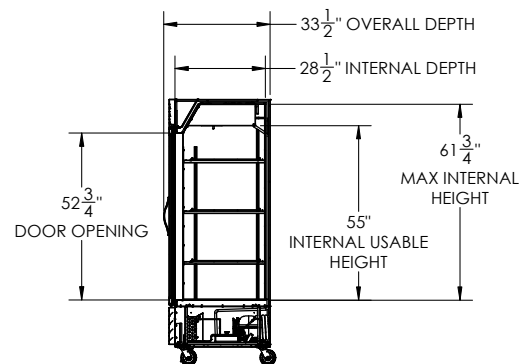

### SIDE VIEW

### ELECTRICAL CONNECTION



115/60/1  
NEMA 5-20P

Unit pre-wired at factory and include 8' long cord and plug set.

