

AMERICAN RANGE®

A  Company

Project _____

Item # _____

Quantity _____

AHS HORIZONTAL BROILER

GAS TYPE: NATURAL LP



- AHS-4827 AHS-6027
- AHS-4836 AHS-6036

STANDARD FEATURES

- Stainless steel exterior body
- Two pieces, includes broiler and stand on legs
- 27" or 36" depth, for high production broiling surface
- Round rod design for cooking spatchcock whole chickens
- High 40,000 BTU/hr. burners for even heat distribution
- Open bottom grate design allows continuous updraft for optimum fuel combustion
- Heavy duty liner protects interior from burn out
- Two year limited parts and labor warranty

OPTIONAL FEATURES

- Optional stand and casters



Model AHS-4836
(shown with optional stand and casters)

DESCRIPTION

American Range Chicken Broiler model AHS. Designed for chicken with stainless steel exterior, round grates, and 40,000 BTU/hr. burners. Unit comes in two pieces, broiler and stand with legs. Open bottom grate design allows continuous updraft for optimal cooking. Two year limited warranty.



DESIGNED & BUILT IN USA
PROFESSIONAL COOKING EQUIPMENT

AMERICAN RANGE®

A  Company

A70244 RevC 08082024

13592 Desmond St Pacoima CA 91331
T. 818.897.0808 Toll Free: 888.753.9898
www.AmericanRange.com

HORIZONTAL BROILERS

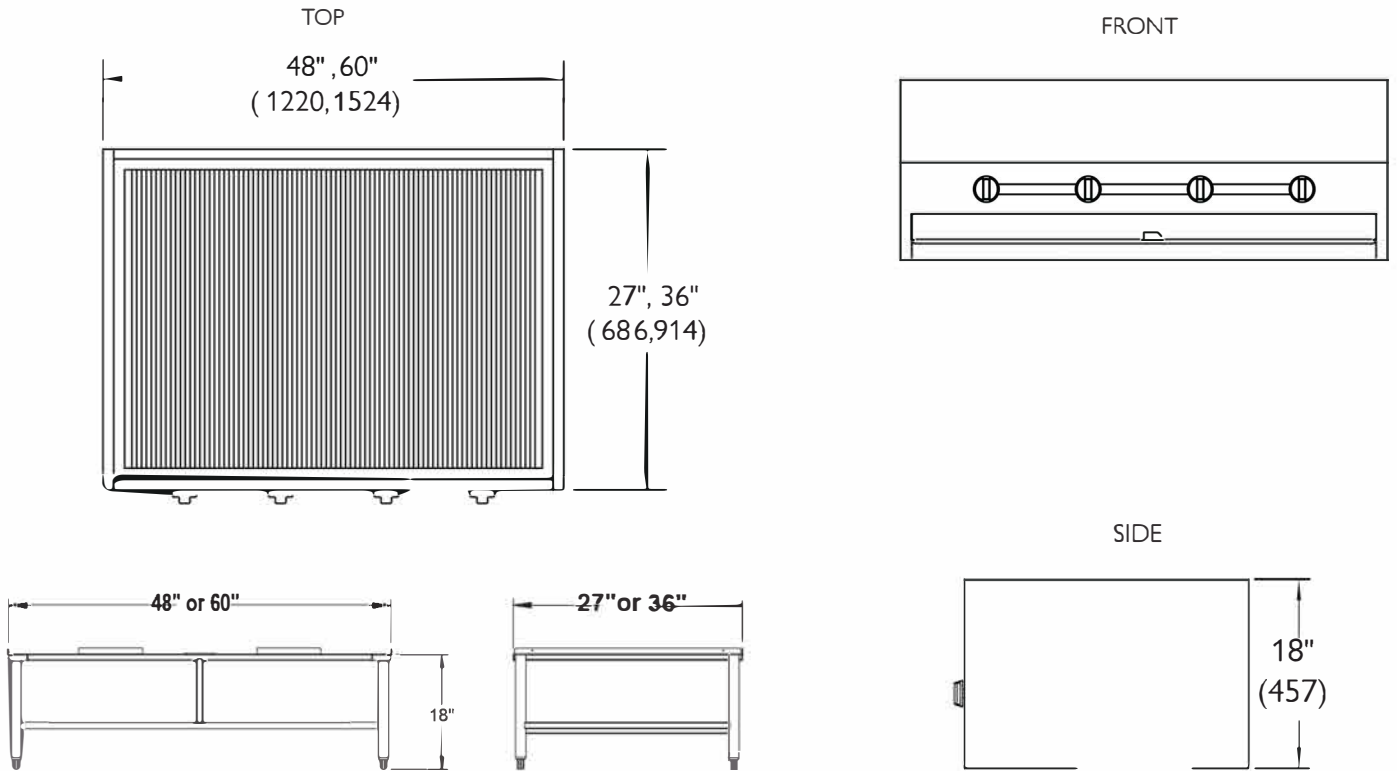

SHIPPING WEIGHT*

MODEL	BURNERS	WIDTH (MM)	DEPTH (MM)	HEIGHT (MM)	BTU	(KW)	LBS	(KG)
AHS-4827	4	48" (1220)	27" (686)	18" (457)	160,000	(47)	270	(122)
AHS-6027	5	60" (1524)	27" (686)	18" (457)	200,000	(59)	370	(167)
AHS-4836	4	48" (1220)	36" (915)	18" (457)	160,000	(47)	300	(136)
AHS-6036	5	60" (1524)	36" (915)	18" (457)	200,000	(59)	400	(181)

• Specify type of gas and altitude if over 2000 feet.

COMBUSTIBLE WALL CLEARANCES:

For use only on non-combustible floors. Legs or casters are required, or 2" (51) overhang is required when curb mounted. Clearance from non-combustible walls is 0". When unit is placed next to combustibile walls, clearances must exceed 12" (305) from sides, and 4" (102) from rear. Radiant broilers for non-combustible locations only.

Commercial cooking equipment requires an adequate ventilation system. For additional information, refer to the National Fire Protection Association's standard NFPA96 "Vapor Removal from Cooking Equipment." (NOTE: For North America only)

NATURAL GAS	MANIFOLD PRESSURE		MANIFOLD SIZE
	PROPANE GAS		
5.0" W.C.	10.0" W.C.		3/4" (19MM)

NMFCODE: 25970-2 Class:

85

Shipping weight includes packaging and is approximate.

American Range is a quality manufacturer of commercial cooking equipment. Because of continuing product improvements these specifications are subject to change without prior notice.



AMERICAN RANGE®

A **Latco** Company

13592 Desmond St Pacoima CA 91331
T. 818.897.0808 Toll Free: 888.753.9898

www.AmericanRange.com