



# BEVERAGE-AIR

Project: _____	AIA#
Item: _____	
Location: _____	SIS#
Approved: _____	

# WTR34HC WORKTOP REFRIGERATOR

## SHALLOW DEPTH WORKTOP REFRIGERATOR

WTR34HC Solid Door With Flat Top  
Hydrocarbon Series

MODEL:  
WTR34HC-FLT



\*Note: Shown with optional full electronic control

**7 Year Parts/Labor Warranty**  
**7 Year Compressor Warranty**

### CABINET CONSTRUCTION

- Stainless steel front, sides, door and grille (galvanized back & bottom)
- Interior liner is made of corrosion resistant aluminum
- Stainless steel top for added durability
- Flat top
- Mechanical control
- Interior thermometer is standard
- Self-closing doors with 120° stay-open feature, on lift-off hinges
- Magnetic gasket attached to each door for positive seal
- 6" Casters, two (2) with brakes standard
- Four (4) epoxy-coated steel wire shelves
- Field-reversible doors (hinge kit not included)

### OPTIONS & ACCESSORIES

- Stainless steel back
- Stainless steel interior
- 16 Gauge stainless steel top
- Full electronic control\*
- Additional shelves
- Shelf clips
- Glass door option
- Right or left hinged door
- Locks (solid doors only)
- Wire shelf divider
- Cutting board
- 3" Casters
- 6" Legs (stainless steel, black or seismic/flange)
- Low profile casters
- Roller kit
- Remote option\*\* (see note on back on page)

### REFRIGERATION SYSTEM

- Uses environmentally friendly, energy efficient R290 refrigerant, and meets all regulatory requirements for CARB, SNAP, DOE & more
- Adaptive defrost
- Epoxy coated evaporator coil
- Refrigerators capable of maintaining product temperature between 36°F and 38°F



Please verify qualifying units by visiting:  
[www.energystar.gov/cfs](http://www.energystar.gov/cfs)

3779 Champion Blvd., Winston-Salem, NC 27105  
1-888-845-9800 Fax: 1-336-245-6453  
Beverage-Air.com Sales@bevair.com



# BEVERAGE-AIR

## Worktop Refrigerator - Shallow Depth Model: WTR34HC-FLT

MODEL	WTR34HC-FLT
<b>EXTERNAL DIMENSIONAL DATA</b>	
Width Overall	34"
Depth Overall with Handle & Bumper	24 5/8"
Height Overall with 6" Casters	32 1/8"
Number of Doors	2
Depth with Door Open 90°	38 1/8"
Door Openings	13 1/8" x 18"
<b>INTERNAL DIMENSIONAL DATA</b>	
NET Capacity (cubic ft.)	5.96
Internal Width Overall (in)	30"
Internal Depth Overall (in)	13"
Internal Height Overall (in)	19 1/2"
Number of Shelves	4
<b>ELECTRICAL DATA</b>	
Full Load Amperes	2.0
Voltage	115/60/1
Nema Plug (8' cord)	5-15P
<b>REFRIGERATION DATA</b>	
Horsepower	1/6
Capacity (BTU/Hr)	1110
Heat Rejection (BTU/Hr)	1665
Charge (lbs/grams/ounces)	0.1323 / 60 / 2.12
<b>SHIPPING DATA</b>	
Gross Weight - Crated	174 lbs
Height - Crated	43"
Width - Crated	30"
Depth - Crated	32"

\*\*NOTE: Remote units are field wired and come with 6" legs.  
Refrigerant must be specified at time of order.

We reserve the right to change specifications and product design without notice. Such revisions do not entitle the buyer to corresponding changes, improvements, additions or replacements for previously purchased equipment. Dimensional tolerances +/- 1/4". Metric dimensions (MM).

### Model Views

Required Clearance: 3" Bottom & 2" Rear

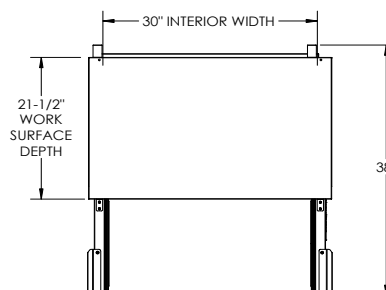

### PLAN VIEW

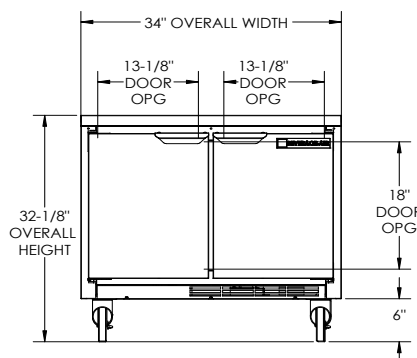

### ELEVATION VIEW

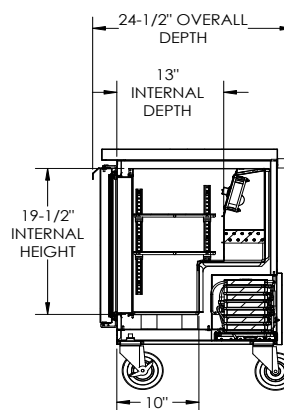

### SIDE VIEW

### ELECTRICAL CONNECTION



115/60/1  
NEMA 5-15P

Unit pre-wired at factory and include 8' long cord and plug set.

