



BEVERAGE-AIR

Project: _____	AIA#
Item: _____	
Location: _____	SIS#
Approved: _____	

FB72HC BOTTOM MOUNT: VISTA® SERIES

VISTA® BOTTOM MOUNT REACH-IN FREEZER

**MODEL:
FB72HC-1S**

FB72HC Solid Door Reach-In Freezer
Hydrocarbon Series



**7 Year Parts/Labor Warranty
7 Year Compressor Warranty**

CABINET CONSTRUCTION

- Stainless steel front and door, gray painted sides
- Gray painted aluminum interior
- Full electronic control
- LED lighting
- Door locks
- Self-closing doors with 120° stay-open feature, on spring-loaded hinges
- One-piece grille allow easy removal/installation for preventative maintenance
- Nine (9) heavy duty epoxy coated wire shelves standard
- 6" Casters standard with (2) brakes

OPTIONS & ACCESSORIES

- Stainless steel universal tray slide (AC)
- Additional epoxy shelves
- Shelf clips
- 3" Casters or 6" legs
- 6" Flanged/seismic feet
- Remote option* (see note on back page)

REFRIGERATION SYSTEM

- Uses environmentally friendly, energy efficient R290 refrigerant, and meets all regulatory requirements for CARB, SNAP, DOE & more
- Adaptive defrost
- Epoxy coated evaporator coil
- Maintains product temperatures of 0° F and below



Please verify qualifying units by visiting:
www.energystar.gov/cfs

3779 Champion Blvd., Winston-Salem, NC 27105
1-888-845-9800 Fax: 1-336-245-6453
Beverage-Air.com Sales@bevair.com



BEVERAGE-AIR

MODEL	FB72HC-1S
EXTERNAL DIMENSIONAL DATA	
Width Overall	75"
Depth Overall with Handle	33 3/4"
Height Overall	84 1/8"
Number of Doors	3
Depth with Door Open 90°	55 1/4"
Door Openings (in)	21 7/8" x 52 3/4"
INTERNAL DIMENSIONAL DATA	
NET Capacity (cubic ft.)	68.43
Internal Width Overall (in)	72"
Internal Depth Overall (in)	28 1/2"
Internal Height Overall (in)	61 3/4"
Internal Height Useable (in)	55"
Number of Shelves	9
ELECTRICAL DATA	
Full Load Amperes	13.9
Voltage	115/60/1
Nema Plug (8' cord)	5-20P
REFRIGERATION DATA	
Horsepower	(2) 3/4
Capacity (BTU/Hr)	(2) 2097
Heat Rejection (BTU/Hr)	6291
Charge (lbs/grams/ounce)	(2) .2094 / 95 / 3.4
SHIPPING DATA	
Gross Weight (crated lbs)	725 lbs
Height - Crated	84"
Width - Crated	78"
Depth - Crated	36"

*NOTE: Remote units are field wired and come with 6" legs.
Refrigerant must be specified at time of order.

We reserve the right to change specifications and product design without notice. Such revisions do not entitle the buyer to corresponding changes, improvements, additions or replacements for previously purchased equipment. Dimensional tolerances +/- 1/4". Metric dimensions (MM).

VISTA® Bottom Mount Reach-In Freezer Model: FB72HC-1S

Model Views

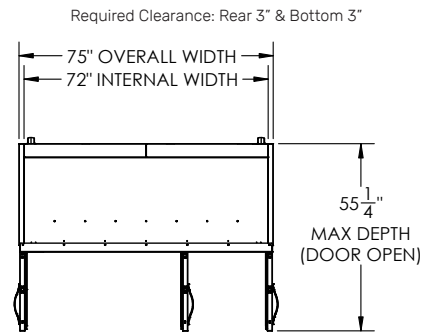

PLAN VIEW

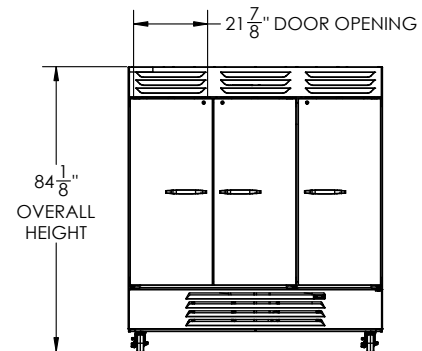

ELEVATION VIEW

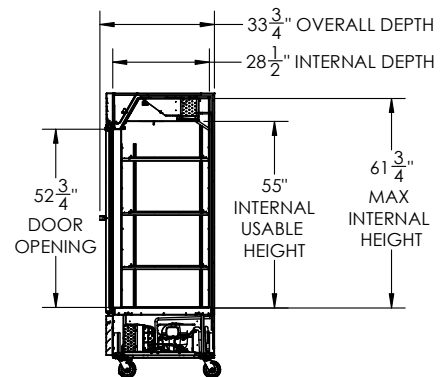

SIDE VIEW

ELECTRICAL CONNECTION



115/60/1
NEMA 5-20P

Unit pre-wired at factory and include 8' long cord and plug set.

