



# STAINLESS STEEL DOUBLE SIDED SELF-SERVE BUFFET SHELF With Built-in Food Shield

Item #: \_\_\_\_\_ Qty #: \_\_\_\_\_

Model #: \_\_\_\_\_

Project #: \_\_\_\_\_



### FEATURES:

- 19-1/4" high.
- Built-in double sided acrylic food shields.
- Food shields have 10" clearance from deck.
- Removable stainless steel top shelf.
- Optional acrylic side panels available to further meet additional NSF requirements (2 panels per end).
- Field installation available.



**Acrylic Side Panels for Buffet Shelf**

Add side panels to meet additional NSF requirements (2 panels per end)

**TBP-1 One End**  
**TBP-2 Two Ends**

Field Installation Available

MODEL	Length (L)		Wt.	Cubic Feet
TBS-2	32"	Fits 2-Well Unit	34 lbs.	2
TBS-3	47-3/8"	Fits 3-Well Unit	42 lbs.	3
TBS-4	62-5/8"	Fits 4-Well Unit	47 lbs.	4
TBS-5	78"	Fits 5-Well Unit	55 lbs.	4
TBS-6	93-1/8"	Fits 6-Well Unit	63 lbs.	4

### MATERIAL:

- Shelf:** stainless steel
- Food Shields:** acrylic

## DETAILS and SPECIFICATIONS

TOL Overall: ± .500" Interior: ± .250"

ALL DIMENSIONS ARE TYPICAL

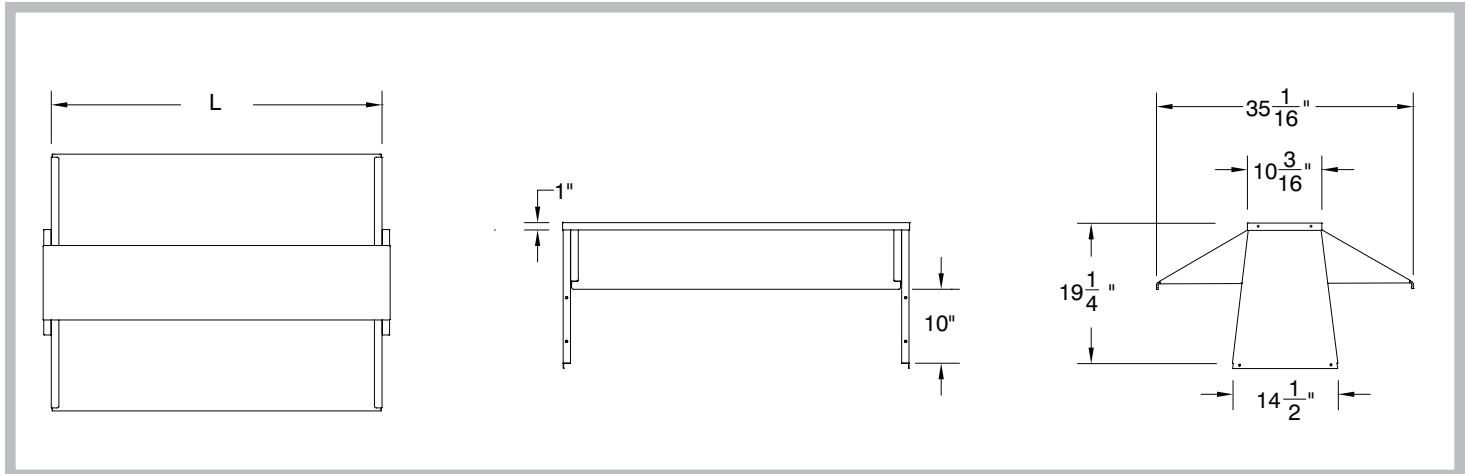



ADVANCE TABCO  
SMART FABRICATION™  
www.advancetabco.com

**Customer Service Available To Assist You 1-800-645-3166 8:30 am - 7:00 pm E.S.T.**

For Orders & Customer Service:  
Email: customer@advancetabco.com or Fax: 631-242-6900

For Smart Fabrication™ Quotes:  
Email: smartfab@advancetabco.com or Fax: 631-586-2933