



BEVERAGE-AIR

Project: _____	AIA#
Item: _____	
Location: _____	SIS#
Approved: _____	

SM49HC SINGLE ACCESS, COLD WALL: SCHOOL MILK SERIES

SCHOOL MILK COLD WALL COOLER

SM49HC Single Access Cooler
Hydrocarbon Series

MODEL:
SM49HC-W



7 Year Parts/Labor Warranty
7 Year Compressor Warranty

CABINET CONSTRUCTION

- White coated steel exterior
- Interior features a one-piece, stainless steel back, front, floor with galvanized side walls for maximum milk crate support
- Stainless steel lids, hinged door and door latches
- Self-latching doors/lids with safety bumpers
- Full electronic control
- Heavy-duty epoxy coated steel wire floor racks standard
- Floor drain is centrally located for easy cleaning and connecting to drain hose with hose adapter
- Flexible compression door gaskets, ensures a tight seal
- Exterior thermometer
- Cylinder lock
- 4" Heavy-duty plate casters (2 with locks)
- Cold wall milk coolers are designed to hold product temperature during service. Product should be removed at the end of service and moved to long-term, refrigerated storage

OPTIONS & ACCESSORIES

- Stainless steel interior on white models -02
- Corner bumpers
- Cafeteria tray slides
- Graphics

REFRIGERATION SYSTEM

- Uses environmentally friendly, energy efficient R290 refrigerant, and meets all regulatory requirements for CARB, SNAP, DOE & more
- Maintains product temperature between 36°F to 40°F



Please verify qualifying units by visiting:
www.energystar.gov/cfs

3779 Champion Blvd., Winston-Salem, NC 27105
1-888-845-9800 Fax: 1-336-245-6453
Beverage-Air.com Sales@bevair.com



BEVERAGE-AIR

School Milk Cooler - Single Access

Model: SM49HC-W

MODEL	SM49HC-W
EXTERNAL DIMENSIONAL DATA	
Width Overall (in)	49"
Depth Overall (in)	30 ⁵ / ₈ "
Height Overall with Casters (in)	41 ¹ / ₈ "
Number of Lids/Doors	Single Access
Depth with Door Open 90° (in)	45 ¹ / ₂ "
INTERNAL DIMENSIONAL DATA	
NET Capacity (cubic ft.)	20.32
Internal Width Overall (in)	46"
Internal Depth Overall (in)	27"
Internal Height Overall (in)	25 ³ / ₄ "
CASE CAPACITY	
13" X 13" X 11"	12
19" X 13" X 11"	8
ELECTRICAL DATA	
Full Load Amperes	2.2
REFRIGERATION DATA	
Horsepower	1/3
Capacity (BTU/Hr)	1367
Heat Rejection (BTU/Hr)	2050.5
Charge (lbs/grams/ounces)	0.1764 / 80 / 2.82
SHIPPING DATA	
Gross Weight - Crated	338 lbs
Height - Crated	48"
Width - Crated	52"
Depth - Crated	34"

We reserve the right to change specifications and product design without notice. Such revisions do not entitle the buyer to corresponding changes, improvements, additions or replacements for previously purchased equipment. Dimensional tolerances +/- 1/4". Metric dimensions (MM).

Model Views

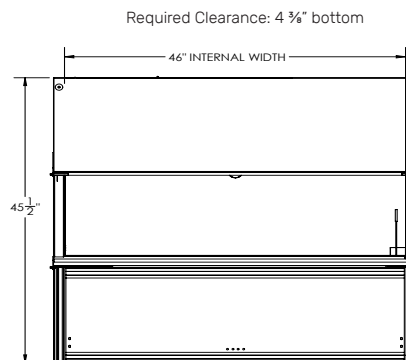

PLAN VIEW

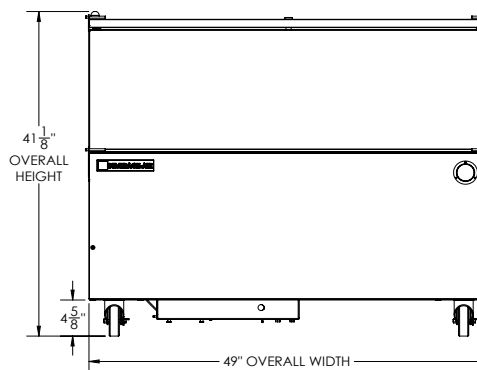

ELEVATION VIEW

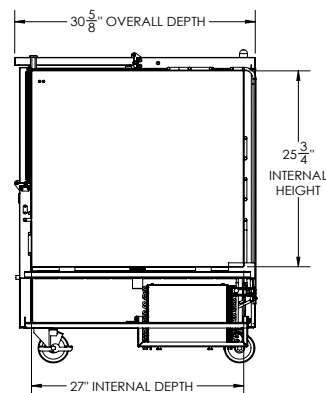

SIDE VIEW

ELECTRICAL CONNECTION



115/60/1
NEMA 5-15P

Unit pre-wired at factory and include 8' long cord and plug set.

