

REFRIGERATOR MANUFACTURER
Turbo air
 more durable, efficient, beautiful

4184 E. Conant St.
 Long Beach, CA 90808
 Tel. 310-900-1000
 Fax. 310-900-1077
www.turboairinc.com

Project:	
Model #:	
Item #:	
Available W/H:	Qty:
Approval:	
AIA #:	SIS #:
CSI Section 11400	

Jumbo Glass Door Freezer

Swing Door Merchandisers
 Super Deluxe Series

TJMF-55SDW(B)-N

FEATURES & BENEFITS

Self-Cleaning Condenser

The accumulation of dust in the condenser can cause the failure or breakdown of refrigerators. Refrigerators run normally until they reach a certain level of accumulation. At some point, when they are over the limit, their performance drops quickly resulting in damage to, or disposal of the stored products inside. The Self-Cleaning Condenser device keeps the condenser clean and prevents system failure by automatically brushing daily.

Digital temperature control & monitor system

- Keeps food products safe by maintaining constant temperatures
- Alarms that sound when doors are not sealed shut; protect against food spoilage that originates from cold air leaks
- Early Warning Alarm program detects issues before malfunction occurs
- Digital display allows for easy monitoring.
- Programs interpret the condition of refrigeration systems by self-diagnosis
- Rapid cool-down function (Turbo Freeze)
- Automatic evaporator fan motor delays

Hydrocarbon refrigerants (R-290)

With innovative and eco-friendly technology, Turbo Air brings you hydrocarbon refrigerators designed to meet DOE's Energy Conservation Standards in 2017 and to use EPA's SNAP Program approved HC refrigerants. Hydrocarbon refrigerants do not deplete the ozone layer and have very low contribution to global warming (ODP-0, GWP-3).

Energy conserving fan control

Utilizing algorithmic air circulation for optimal temperature levels, our innovative fan control system conserves energy by at least 15% and increases compressor life by up to 30%.

No electrical cabinet heater is needed

Turbo Air is the first in the industry to replace a frame heater with a method of using compressor-produced heat. This eliminates any unnecessary energy consumption while providing efficient freezing performance.

Triple pane heated glass doors

Equipped with unique triple-pane heated glass doors which enhance energy efficiency by preventing heat transfers and minimizing condensation. Lightweight door construction reduces door maintenance, bushing wear, and facilitates smooth door opening.

High-density polyurethane insulation

The entire cabinet structure is foamed-in-place using high density, CFC free polyurethane insulation.

LED interior lighting

Freezer holds -10°F ~ 5°F for the best in frozen food preservation



TJMF-55SDW-N

TJMF-55SDB-N

Patented Self-Cleaning Condenser

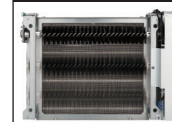

This product is equipped with a fine mesh filter to the front of the condenser to catch dust, and a rotating brush that moves up and down daily to remove excess buildup outward and away.

Benefits over Remote Units

- Loading capacity is the same as an endless remote unit
- No plumbing required
- No installation work required
- Low maintenance expenses
- Energy saving
- Easy to relocate

NATURAL Refrigerant

SPEC ISO 9001:2008

ETL Intertek

ETL Intertek

5 YEAR WARRANTY

Compressor 7 YEAR WARRANTY

ENERGY STAR® Qualified

Model	Swing Doors	CU./FT.	#of Shelves	HP	AMPS	Crated Weight (lbs.)	L x D* x H (inches)
TJMF-55SDW(B)-N	2	60.04	12	1/2 x 2	10.5	798	65 1/8 x 38 x 83 1/2

Jumbo Glass Door Freezer

Swing Door Merchandisers
Super Deluxe Series

Model : TJMF-55SDW(B)-N

ELECTRICAL DATA	
Voltage	115/60/1
Plug Type	 NEMA 5-20P
Full Load Amperes	10.5
Compressor HP	1/2 x 2
Cord Length (ft.)	8.5
Refrigerant	R-290
DIMENSIONAL DATA	
# of Doors	2
Net Capacity (cu. ft.)	60.04
Ext. Length Overall (in.)	65 1/8 (1654mm)
Ext. Depth Overall (in.)*	38 (965mm)
Ext. Height Overall (in.)	83 1/2 (2120mm)
Int. Length Overall (in.)	60 (1524mm)
Int. Depth Overall (in.)	30 1/2 (775mm)
Int. Height Overall (in.)	58 5/8 (1489mm)
# of Shelves	12
Shelf Size (L x D) (in.)	29 x 29
Net Weight (lbs.)	701
Gross Weight (lbs.)	798

Design and specifications subject to change without notice.
Actual shipping weight may differ due to extra packing materials for product protection.
* Depth does not include 2-1/4" for door handle.

- **WARRANTY : 5 Year Parts and Labor Warranty**
7 Year Compressor Warranty

■ STANDARD FEATURES

- **Anti-corrosion coated evaporator**
- **Adjustable PE (polyethylene) coated wire shelves**
- **White and black colors come standard**

** Lead time applies. Please contact your sales representative for more details to order.

PLAN VIEW

(unit : inch)

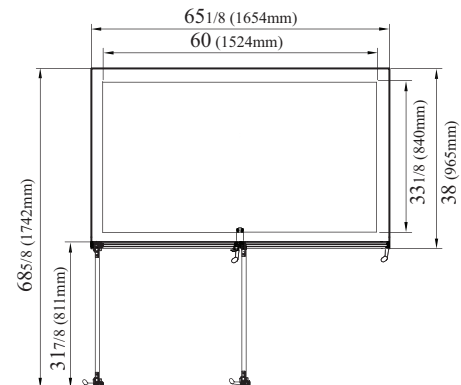

TOP VIEW

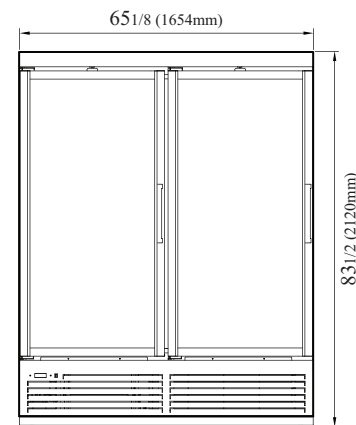

FRONT VIEW

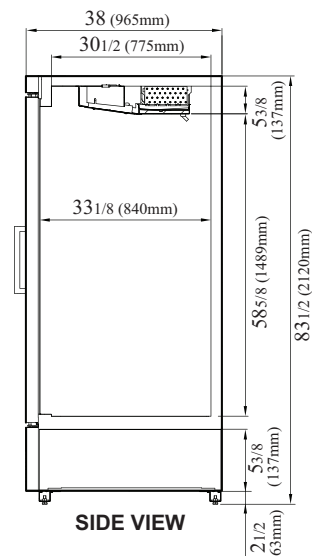

SIDE VIEW

Ver.20240403

NATURAL Refrigerant



ENERGY STAR® Qualified

- Turbo Air: 800-627-0032
- Radiance: 800-500-3519
- Warranty: 800-381-7770
- AC: 888-900-1002

Turbo air REFRIGERATOR MANUFACTURER

RADIANCE

Turbo air REFRIGERATION SYSTEM

TEXAKING

Continued product development may necessitate specification changes without notice.