

- A distinctive tower with crisp lines defining its shape.
- All stainless steel product contact.
- Available in either glycol cooled or air cooled.

**E-G5-2-C-A**

Chrome (Air Cooled)

E-G5-2-C-G

Chrome (Glycol Cooled)

Medallion Version Available: **E-G5-2-C-G-M***

Faucet knobs not included.



Part No.	Faucets	Finish	Dispense System	Shipping Weight
<input type="checkbox"/> E-G5-2-C-A	2	Chrome	Air Cooled	TBD
<input type="checkbox"/> E-G5-2-C-G	2	Chrome	Glycol Cooled	TBD

Medallion Version Available: E-G5-2-C-G-M*

Dimensions

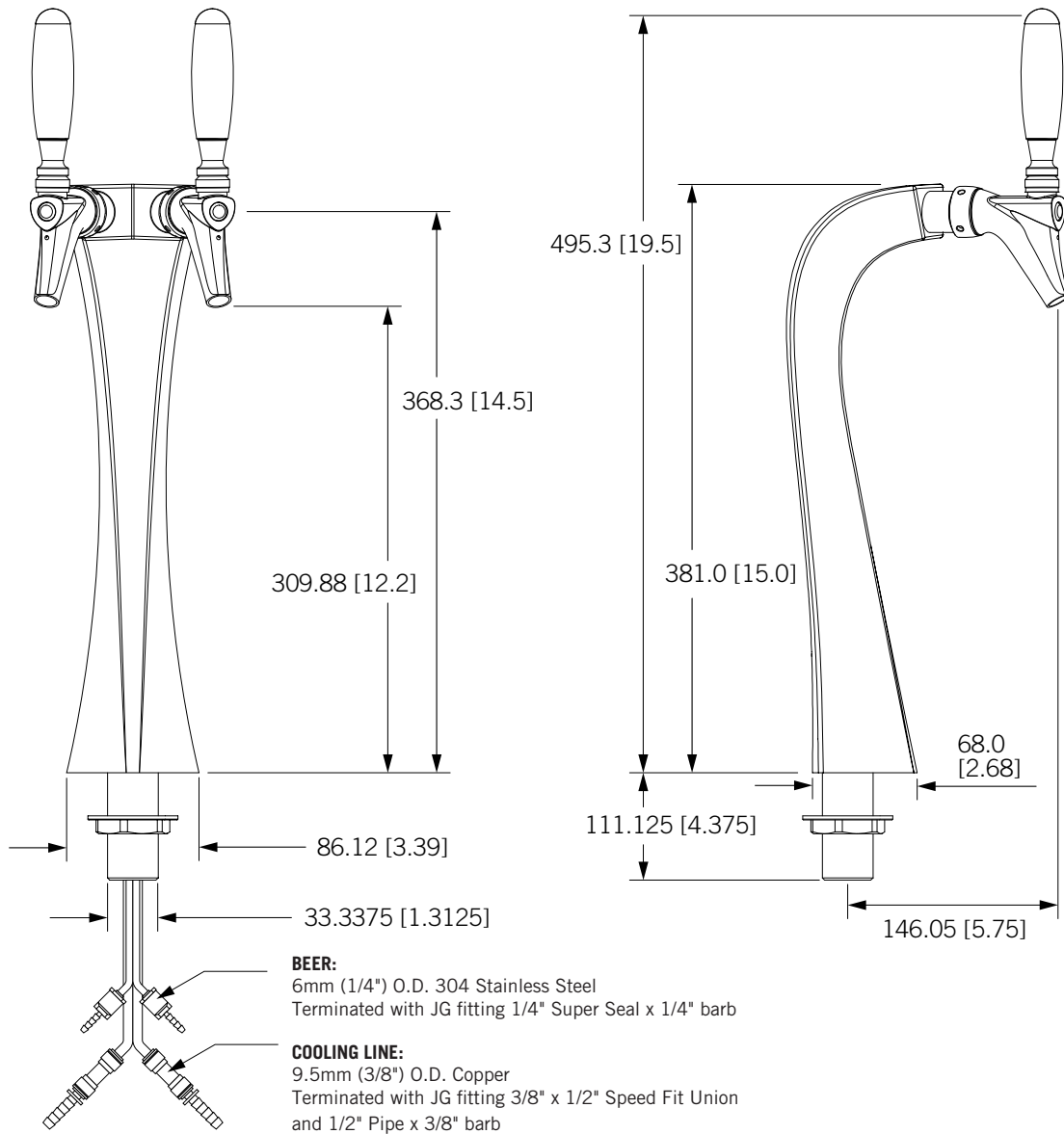

West
19791 Bahama St.
Northridge, CA 91324
Tel. (818) 701-9765
Fax. (818) 701-9844

Central
10726 North Second St.
Machesney Park, IL 61115
Tel. (815) 968-7557
Fax. (815) 968-0363

Southeast
15111 Dispense Ln.
Brooksville, FL 34604
Tel. (352) 799-6331
Fax. (352) 796-2429

Northeast
4601 Saucon Creek Rd.
Center Valley, PA 18034
Tel. (610) 625-4464
Fax. (610) 625-4466