

# SPECIFICATION SHEET

## DSA400 | DOUGH DIVIDER ROUNDER

SEMI-AUTOMATIC DOUGH DIVIDER/ROUNDER, AVAILABLE IN 15, 22, 30, 36 & 54 PORTIONS, INCLUDES (3) SANITARY PLASTIC ROUNDING PLATES, STAINLESS STEEL CUTTING BLADES, WHEEL MOUNTED, INTERCHANGEABLE DOUGH HEAD, ETL



<b>PROJECT</b>
<b>ITEM NO.</b>
<b>NOTES</b>
<b>MODEL NUMBER:</b> DSA4330, DSA4336, DSA4354, DSA4415, DSA4422, DSA4430, DSA4436



STAINLESS STEEL [SUFFIX I]



## FEATURES

<input type="checkbox"/> REMOVABLE AND INTERCHANGEABLE DIVISION HEADS
<input type="checkbox"/> SEMI-AUTOMATIC DIVIDING & ROUNDING
<input type="checkbox"/> ROBUST CONSTRUCTION
<input type="checkbox"/> SANITARY DOUGH PRESS HEAD + [3] ROUNDING PLATES
<input type="checkbox"/> ANTI-VIBRATION SYSTEM IN STAINLESS STEEL
<input type="checkbox"/> FLOOR RAISED WITH CASTORS
<input type="checkbox"/> QUIET OPERATION
<input type="checkbox"/> DIVIDES DOUGH WITH OPTIMAL HYDRATION OF 55-65%
<input type="checkbox"/> EASY SNAP ON & OFF HEAD COVER
<input type="checkbox"/> EQUIPPED WITH FREE SPARE PARTS KIT (SPRINGS & DAMPER)

## CONSTRUCTION

<input type="checkbox"/> STANDARD WHITE PAINTED CARBON STEEL FRAME
<input type="checkbox"/> STAINLESS STEEL AISI 304 ARC HEAD SUPPORT
<input type="checkbox"/> STAINLESS STEEL AISI 304 CUTTING BLADES
<input type="checkbox"/> DOUGH PRESS & RING BUILT IN DIN POM C
<input type="checkbox"/> 6 FOOT POWER CORD WITH PLUG
<input type="checkbox"/> ANTI-VIBRATION SYSTEM IN STAINLESS STEEL
<input type="checkbox"/> FLOOR RAISED WITH CASTORS

## CONFIGURATIONS

MODEL	PORTIONS	PORTION WEIGHT (OZ/GRAMS)*		DOUGH CAPACITY	
		MIN.	MAX.	MIN.	MAX.
<input type="checkbox"/> DSA4330	30	1.00/30	3.50/100	900 G	3.0 KG
<input type="checkbox"/> DSA4336	36	0.87/25	3.00/80	900 G	3.0 KG
<input type="checkbox"/> DSA4354	54	0.50/15	1.50/40	810 G	3.0 KG
<input type="checkbox"/> DSA4415	15	3.00/85	10.50/300	1.30 KG	4.5 KG
<input type="checkbox"/> DSA4422	22	2.11/60	7.00/200	1.30 KG	4.5 KG
<input type="checkbox"/> DSA4430	30	1.50/40	4.75/135	1.25 KG	4.0 KG
<input type="checkbox"/> DSA4436	36	1.25/35	4.00/110	1.25 KG	4.0 KG

\*Minimum and maximum capacities will depend on fermentation, hydration and flours used. Variance of individual portion weight is subject to change dependent on dough formulation and proper operation of unit.

## OPTIONS & ACCESSORIES

<input type="checkbox"/> STAINLESS STEEL AISI 304 FRAME & BODY	ADD SUFFIX "-I"
<input type="checkbox"/> REMOVABLE HEAD $\phi$ 410MM: 15, 22, 30, 36 DIVISIONS	DSA4415, DSA4422, DSA4430, DSA4436
<input type="checkbox"/> REMOVABLE HEAD $\phi$ 364MM: 30, 36, 54 DIVISIONS	DSA4330, DSA4336, DSA4354
<input type="checkbox"/> ROUNDING COLLAR $\phi$ 410MM	30226000300231
<input type="checkbox"/> ROUNDING COLLAR $\phi$ 364MM	30226300000011
<input type="checkbox"/> ROUNDING PLATES $\phi$ 410MM	PDS.DSA4XX
<input type="checkbox"/> ROUNDING PLATES $\phi$ 364MM	PDS.DSA3XX
<input type="checkbox"/> 220 VOLTS	ADD SUFFIX "-220"

## WARRANTY

ONE YEAR LABOR & TWO YEAR PARTS LIMITED WARRANTY

Due to periodic changes in designs, methods, procedures, policies and regulations, the specifications contained in this sheet are subject to change without notice. While Doyon exercises good faith efforts to provide information that is accurate, we are not responsible for errors or omissions in information provided or conclusions reached as a result of using these specifications. By using the information provided, the user assumes all risks in connection with such use.

SPECIFICATIONS SUBJECT TO CHANGE WITHOUT NOTICE

KCL & REVIT DRAWINGS UPON REQUEST

REVISION D | 1/15/2025

DOYON

5600 13TH STREET, MENOMINEE, MI 49858

906.863.4401 | 800.338.9886

WWW.DOYONBAKING.COM

<b>PROJECT</b>
<b>ITEM NO.</b>
<b>NOTES</b>
<b>MODEL NUMBER:</b> DSA4330, DSA4336, DSA4354, DSA4415, DSA4422, DSA4430, DSA4436

## DIMENSIONS & WEIGHTS

DIMENSIONS, W/O HANDLE (HxWxD)	[63" x 29 <sup>5/16"</sup> x 28 <sup>3/4"</sup> [1600mm x 760mm x 730mm]
DIMENSIONS, WITH HANDLE (HxWxD)	[77 <sup>3/16"</sup> x 29 <sup>5/16"</sup> x 28 <sup>3/4"</sup> [1960mm x 760mm x 730mm]
SHIPPING DIMENSIONS (HxWxD)	[72" x 48" x 40" [18.3mm x 1219mm x 1016mm]
NET WEIGHT	[665 lbs.] [302 kg]
SHIPPING WEIGHT	[783 lbs.] [355 kg]
CLEARANCE (sides, back, front, top)	[18", 18", 36", 80" [457mm, 457mm, 914mm, 2032mm]
DIMENSION A	[29 <sup>15/16"</sup> ] [760mm]
DIMENSION B	[28 <sup>3/4"</sup> ] [730mm]
DIMENSION C	[77 <sup>3/16"</sup> ] [1600mm]
DIMENSION D	[32 <sup>5/16"</sup> ] [820mm]
DIMENSION E	[31 <sup>5/16"</sup> ] [100mm]
DIMENSION F	[38 <sup>3/16"</sup> ] [970mm]
DIMENSION B1	[38 <sup>9/16"</sup> ] [980mm]
DIMENSION C1	[63"] [1600mm]

## POWER REQUIREMENTS

POWER CONSUMPTION [kW]	0.55
GRID SUPPLY FREQUENCY [Hz]	50/60
VOLTAGE	120
AMPS	8
PHASES	1
NEMA	5-15P 

## DRAWINGS

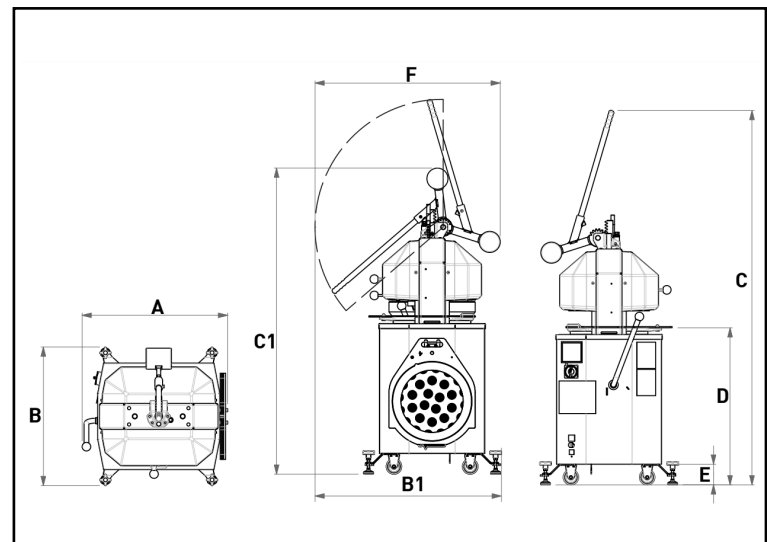

## ACCESSORIES

		
ROUNDING PLATES ø410MM ROUNDING PLATES ø360MM	REMOVABLE HEAD ø410MM: 15, 22, 30, 36 DIVISIONS REMOVABLE HEAD ø360MM: 30, 36, 54 DIVISIONS	ROUNDING COLLAR ø410MM ROUNDING COLLAR ø360MM

## BIDDING SPECIFICATIONS

Semi-automatic dough divider/rounder; sanitary, removable/interchangeable dough press head with stainless steel cutting blades. Three sanitary plastic rounding plates and spare parts kit included. Standard white painted carbon steel frame with snap-on/snap-off head cover; on casters; anti-vibration system. 120 volts, 550 watts, 8 A, 50/60 Hz, single phase. Six foot, three wire rubber cord with 3-prong grounding plug. NEMA 5-15P.