



460 Southport Commerce Blvd.
 Spartanburg SC 29306
 Phone: 864-574-6004
 Fax: 864-574-6005
 www.ojedausa.com
 sales@ojedausa.com

Project: _____
 Model #: _____
 Item #: _____ Qty: _____
 Approval: _____

COUNTERTOP FREEZER

CTFH-3



R-290 REFRIGERANT

Equipped with R-290 refrigerant, an eco-friendly alternative that meets the EPA's environmentally impact regulations.

STEEL CONSTRUCTION

Robust steel construction minimizes the use of plastic materials resulting in an environmental friendly design.

MECHANICAL THERMOSTAT

Temperature control is adjustable to provide a range of temperatures for your personal satisfaction.

OPERATION TEMPERATURE

-10°F to 0°F

CUSTOM GRAPHICS

Standard color: white.

Dimensions			Crated Dimensions			Shelves	HP	Voltage	NEMA config	Amps	Crated Weight		
	W	D	H		W	D	H	2	1/5	120	5-15P	4	185 lbs
(in)	23.6	23.8	29.1	(in)	25.2	25.6	33.1	Net Capacity (cf): 3			Energy Consumption: 2.75 kw-hr/day		
(mm)	600	605	740	(mm)	640	650	840						

*Inches rounded up one decimal place *Specifics may change without notification



CABINET CONSTRUCTION

- High-density, CFC-Free, polyurethane insulation
- Triple pane glass
- Exterior: galvanized metal cabinet with powder coated painted surface
- Interior: easy to clean pre-painted steel
- Stainless steel leveling legs

SHELVING

- Adjustable shelves

OPERATING CONDITIONS

- The unit is best suited for an environment where temperatures remain below 75°F and humidity does not exceed 55%.
- Areas with direct sunlight should also be avoided.

REFRIGERATION

- Easy to reach components for repairs
- Cold wall evaporator
- Adjustable thermostat
- R-290 refrigerant

OPTIONS

- Optional attachable lock with key.
- Custom graphics

WARRANTY

- 3 year parts and labor warranty
- 5 year compressor

LIGHTING

- Horizontal & Vertical LED lighting

LEVELING LEGS



OPTIONAL LOCK WITH KEY

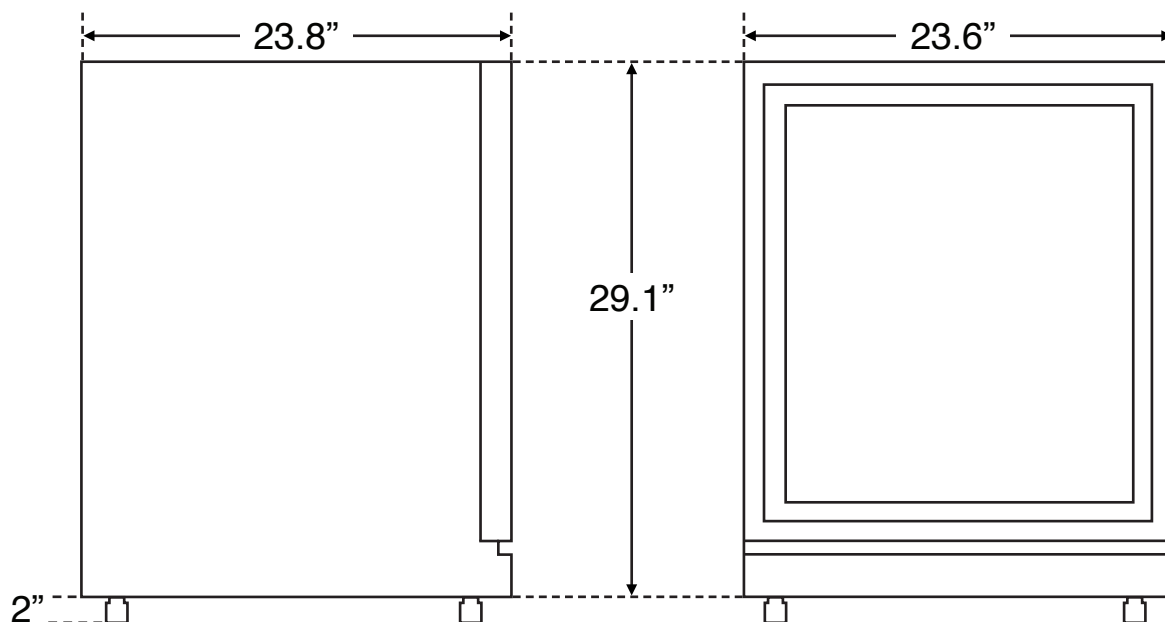

*Specifics may change without notification

