



Rotorbake E11 Master Pro

Electrical Supply

Trays	2X 18T 18" x 26" (46 x 66 cm) TOTAL CAPACITY 36 TRAYS
Outside dimension	61" W x 88.3" D x 98.6" H (1550 W x 2244 D x 2504 H mm)
Tray distance	3.7" (93 mm)
Power	80 kW
Weight	2314.9 lbs (1050 Kg)
Max temperature	518° F (270° C)
AMPS	233 Amps at 3ph
Power supply	230 V ~ 3PH + PE 50-60 Hz

Equipment

BakeAIR multi-fan system	Double low emissive glass	High-performance thermal insulation
USB connection	Five fan speeds and semi-static cooking	Five cooking modes
Automatic chimney opening BakeDRY	Program blocking with password	CE Certificate
Automatic control of dry/steam balance inside the chamber	Steam control in percentage BakeSTEAM	Automatic control of the cooking level and load
Double steamer RotorBake	Multi-timer function for multiple and mixed cooking	Time-programmable steam injection
Manual steam injection	Storage, viewing* and exportation of cooking data (haccp)	Customized programs mode
Manual mode	Preset programs mode	ETL certification
	Automatic preheating	Cooling program
Delayed start programming	Delayed cooking programming	Cooking chamber automatic cooling
Pre-loaded and online cookbook	Automatic detection and errors report	Polypropylene (PP) Exhaust Piping (External)

Options

Ethernet connection and wi-fi set-up BakeNET	S/S external paneling	Double-closing door and double gasket
Rotating platform	Rack automatic lift for Rotorbake	Left door opening



ROTORBAKE E11 Master Pro

Electrical Supply

Features

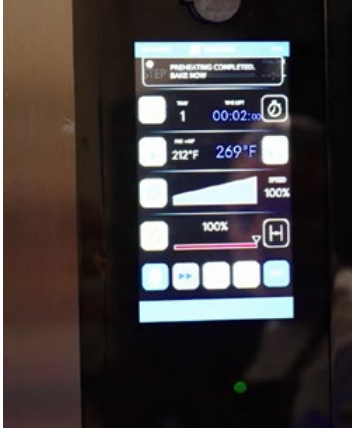

Touch Screen



USB Port

Double Low Emissive Glass

Thermal Insulation

Air gap between internal and external glass allows outer glass to be touched by the operator. The Internal glass has a reflective side to help retain the heat in chamber.

Cooking Programs Available

- Delta T cooking with core probe,
- Pasteurization cooking,
- Convection cooking,
- Vacuum cooking,
- In-vase cooking,
- Steam Cooking,
- Mixed Cooking,
- And More!

Optional Accessories



C500
Water Filter
Cartridge



C500H
Water Filter
Head



410567270
36 Tray Rack

AMPTO is continuously improving products. Specifications are subject to change without notice.

Rotorbake E11 Master Pro

Electrical Supply

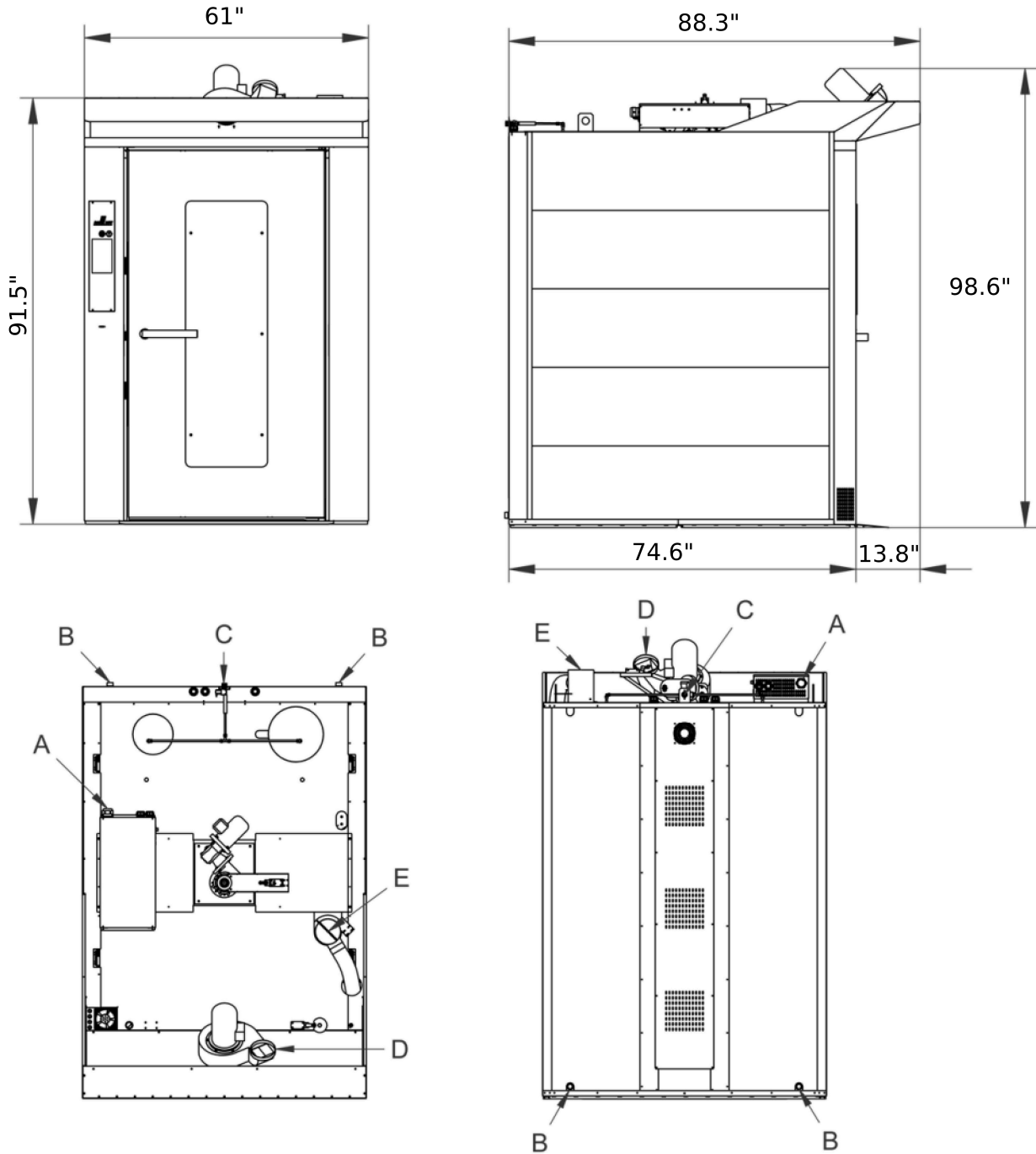

Legend

- A - Power supply inlet
- B - Water discharge 1"
- C - Water inlet 3/4"
- D - Extractor hood discharge
- E - Chamber steam discharge Ø 140

AMPTO is continuously improving products. Specifications are subject to change without notice.

Rotorbake E11 Master Pro

Electrical Supply

Supply and Connections

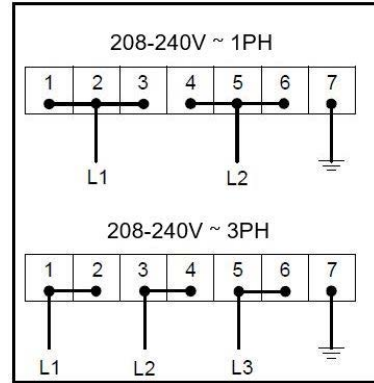
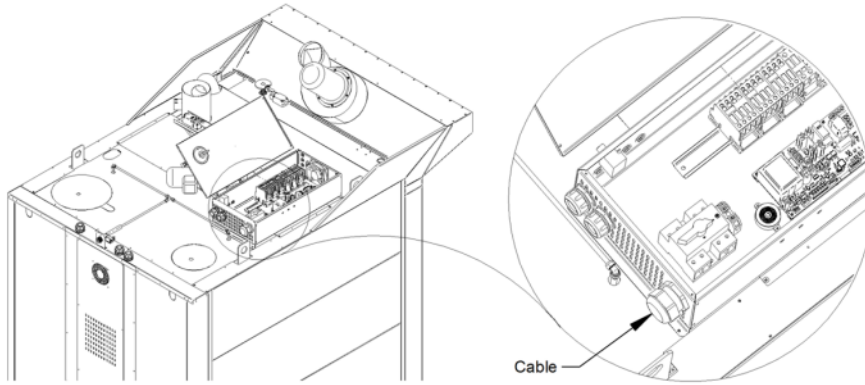

Notes:

- Operate at room temperature between 41° and 104°F (5° and 40°C).
- Clearance of 6" required on all sides
- If the oven is positioned next to other units that give off heat (e.g. fryers), appropriate measures must be taken, such as placing protection against radiance.
- Maximum water hardness of 5°F
- Properly clean and dry after daily use to ensure best performance and equipment longevity.



No Plug
No Cord



Direct Water
Connection



Drain Required

Packaging

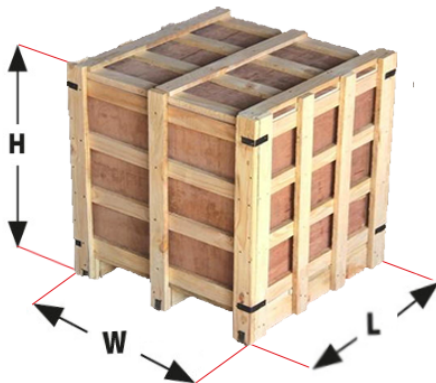

Packing size:

65.4" W x 88.6" D x 100.4" H

1660 L x 2250 D x 2550 H mm

Net weight:

2314.9 lbs (1050 Kg)

Gross weight:

2535.3 lbs (1150 Kg)

AMPTO is continuously improving products. Specifications are subject to change without notice.