

# BLODGETT

Electric Boilerless Tabletop Combi with  
One Touch Control & Hoodini Ventless Hood

## BLCT-6E-H

**The optimal choice when size matters.** The BLCT-6E-H mini combi is a completely unique oven size on the market. With a width of only 20.2" it can fit into even the smallest kitchens. Despite its small size, the BLCT-6E-H mini combi has the same features as a large combi oven.

**Cook the way you want** - the Blodgett One Touch control lets you choose which kind of chef you want to be. You can cook manually and easily fine-tune your settings. Use pre-programmed recipes to ensure consistent, results every time. Or use the SmartChef feature which automatically selects the optimum settings for an effortless cooking process.

**Hoodini is the ultimate in ventless hood technology.** The Hoodini™ hood, designed for the Blodgett MiniCombi, lets you place your oven just about anywhere. The Hoodini removes smoke, odor, and moisture from the oven cavity. Oven fry bacon or roast chickens and breathe easy. Plus you save valuable floor space under the hood.



# HOODINI<sup>\*\*\*</sup>



### CAPACITY

- Standard 2 piece rack that holds five 12" x 20" x 2" deep or four 12" x 20" x 2-1/2" deep North American hotel pans or six half size sheet pans

### STANDARD FEATURES

- Internal core temperature probe with multiple measuring points.
- Bright halogen lights for superior visibility
- Detachable hand shower
- 5 wire shelves
- Left door hinge, field reversible
- Start-up inspection service by factory authorized service agent.
- One year parts and labor oven warranty\*

\* For all international markets, contact your local distributor.

[www.blodgett.com](http://www.blodgett.com)

42 Allen Martin Drive, Essex Junction, VT 05452 • Phone: (802) 658-6600 • Fax: (802) 864-0183

P/N 61714 Rev U (1/25)

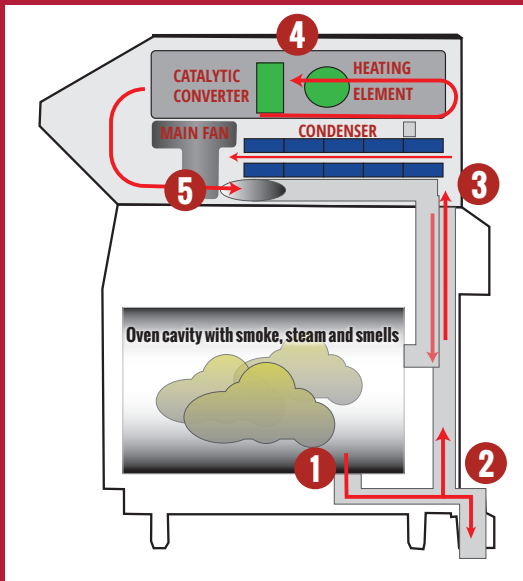

## HOODINI VENTILATION SYSTEM

- Hoodini ventless hood combines catalytic system with condensing system. The condenser removes steam exhaust while the catalyst removes smoke and fumes.
- No filters to change
- Integrated hood - no fire suppression required
- Top clearance required = Zero inches!
- Not for use with FlavorSmoke 450 smoker box
- UL (KNLZ) listed for ventless operation
- Using EPA test method 202, emissions of grease laden vapors were measured at 1.12 mg/m<sup>3</sup> for bone-in, skin-on, quartered roasting chickens, and 0.16 mg/m<sup>3</sup> for bacon. Both results being less than the established 5 mg/m<sup>3</sup> standard.
- Heat output - 1,399 Watts (4,777 BTU/hr)

## CONSTRUCTION

- 430 stainless steel sides, top and back
- 304 stainless steel bottom, door and interior
- Dual pane tempered viewing window with hinged inner glass for easy cleaning
- 1.57" (40mm) fixed drain in the bottom center of cavity
- Drip tray mounted below the door reduces the risk of wet, slippery floors
- CTD Cool Touch Door
- Oven door with ventilated heat-reflecting glass
- Left hinge door is field convertible to the right side
- Two step safety door latch. The first step stops the fan.

## OPTIONS & ACCESSORIES

### (AT ADDITIONAL CHARGE)

- Extra wire oven racks
- Optional stand
- Backflow preventer
- Extra year warranty
- Open Kitchen\*

\*If Customer is purchasing the **Open Kitchen** feature with the equipment, the Customer agrees to the Open Kitchen terms of service, which can be found here: <https://ok.sitesage.net/assets/policy/GeneralTermsAndConditions.pdf>

## OVEN OPERATION

- Injection steam system - water is injected onto the heating elements, the resulting steam is distributed in the oven chamber by the fan wheel.
- Easy to use touchscreen control stores up to 1500 recipes with up to 15 steps each
- Multiple cooking modes include hot air, CombiSpeed, steaming, low-temperature steaming, forced steaming, proofing, preheating
- SmartChef automatic cooking provides presets for grilling, steaming, braising, browning and breaded products. Select your desired cooking result from rare to well done, and your surface appearance from light to dark.
- Manual or automatic cooling
- Automatic humidity pulsing
- Timed steam injection or instant steam on demand at any point in the cook cycle
- Rack timing for setting individual timers for each rack
- Advanced rack timing for timing multiple recipes of the same group simultaneously on separate racks
- Reversible 9 speed fan for optimum baking and roasting results
- Programmable vent release allows for automatic venting if desired
- USB port for data and recipe transfer
- HACCP recording and documentation
- Automated CombiWash system features very low water and detergent consumption and no contact with chemicals. No proprietary chemicals required, see owner's manual for detergent guidelines.

**BLODGETT**®

## DRAIN

The drain piping must consist of temperature resistant material, greater than 160°F, and be of adequate diameter not to cause flow restriction. Improper materials may deform and cause restrictions, thus affecting performance.

Appliance is to be installed with backflow protection in accordance with federal, state or local codes.

**SHORT FORM SPECIFICATIONS:** Provide Blodgett model BLCT-6E-H CombiSlim combination-oven/steamer with ventless hood. The BLCT-6H has a 2 piece rack system that holds five 12" x 20" x 2" deep or four 12" x 20" x 2-1/2" deep North American hotel pans.

Unit has a stainless steel exterior and interior. Oven door has a dual pane tempered viewing window with hinged inner glass for easy cleaning. Includes a detachable hand shower and separate water lines. Unit shall have bright halogen lights for superior visibility and an internal core temperature probe with multiple measuring points. Oven has two separate water lines for cooking and quench. You may choose to cook with pressureless steam, hot air, or combination of steam and hot air.

The Hoodini integrated hood requires no fire suppression or filter.

The One Touch control stores 1500 recipes with 15 stages each, in addition to pre-programmed recipes. Multiple modes include hot air, combi, steaming, low-temperature steaming, forced steaming, proofing, cooling, and preheating. The control allows for timed steam injection or instant steam on demand at any point in the cook cycle. Rack timing provides individual timers for each rack. Advanced rack timing allows for timing multiple recipes of the same group simultaneously on separate racks of the oven. Use SmartChef automatic cooking presets for grilling, steaming, braising, browning and breaded products. HACCP quality control, USB connectivity and automatic service diagnosis are included. Programmable vent release allows for automatic venting if desired. The reversible 9 speed fan provides optimum baking and roasting results. The automated combi wash system features very low water and detergent consumption and no contact with chemicals.

Includes one-year parts and labor warranty. Provide start-up inspection service by a factory authorized service agent. Provide options and accessories as indicated.

*NOTE: The company reserves the right to make substitutions of components without prior notice.*

## POWER SUPPLY

VOLTAGE	KW	PHASE	AMPERAGE
<b>HOOD - dedicated circuit</b>			
120VAC	-	1 Ph	15 amp max.
<b>OVEN</b>			
208 VAC	6.9	1 Ph	35 amp
240 VAC	9.2	1 Ph	39 amp
208 VAC	6.9	3 Ph	20 amp
240 VAC	9.2	3 ph	24 amp

Available in 50 or 60 Hz (specify)

Three phase units equipped with cord and NEMA 15-30P plug. Single phase units equipped with cord and NEMA 6-50P plug.

This appliance uses a variable frequency drive, which can be known to product high frequency electrical noise. In some cases units must be hard wired. This avoids false positives on ground fault devices susceptible to errors from electrical noise. All installations must comply with local and national codes.

## WATER SUPPLY

Good quality water feed is the responsibility of the owner. Water quality must be within the following general guidelines.

TDS: 40-125 ppm	pH: 7.0-8.5
Hardness: 35-180 ppm	Silica: <13 ppm
Chloramine: <0.2 ppm	Chlorine: <0.2 ppm
Chlorides: <25 ppm	

The best defense against poor water quality is a water treatment system designed to meet your water quality conditions. Blodgett offers optional water treatment systems.

### Pressure

- 40 (min)-50 (max) PSI

### Connections

- 1.57" (40mm) drain connection - max. drain temperature 140°F (60°C)
- 3/4" garden hose cold water

**BLODGETT**®

DIMENSIONS ARE IN INCHES (MM)

**LEGEND**

- D DETERGENT
- R RINSE AID
- F FILTERED WATER
- U UNFILTERED WATER
- D DRAIN
- O DRAIN OVERFLOW
- E ELECTRICAL

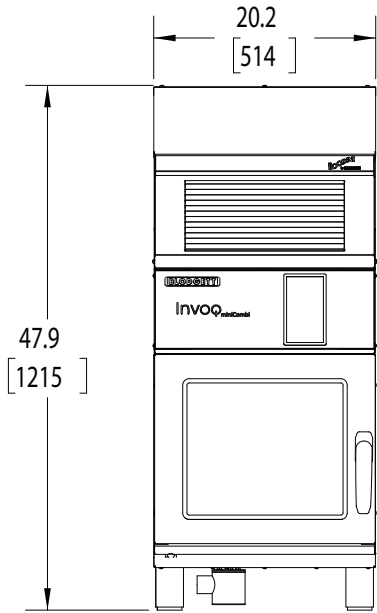

FRONT VIEW

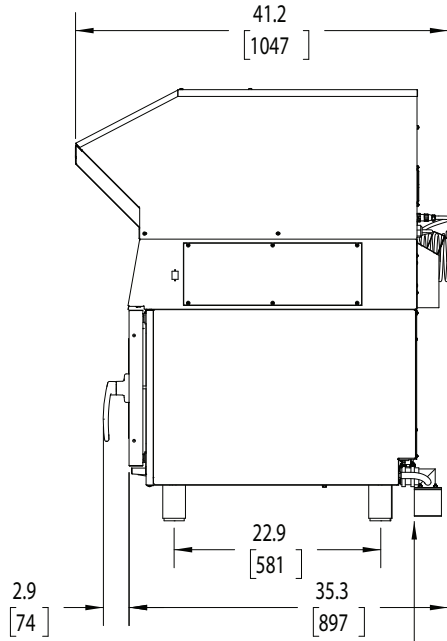

SIDE VIEW

Drain outlet may be rotated 90° in either direction

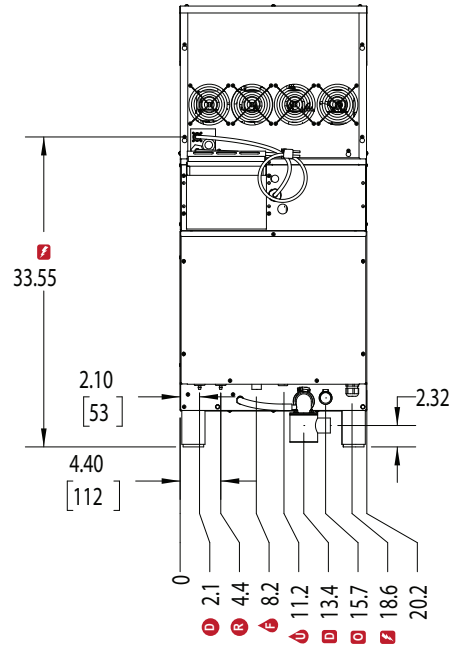

BACK VIEW

**SHIPPING**

**WEIGHT**

340 lbs (154 kg)

**CRATE SIZE**

Oven w/hood

49.75" H x 27" W x 45" D  
(1264 mm x 686 mm x 1143 mm)

**DIMENSIONS & CLEARANCES**

**FLOOR SPACE**

41.1" x 20.2" (1043 x 513mm)

**UNIT HEIGHT**

45.6 (1158mm)

**MINIMUM ENTRY CLEARANCES**

Uncrated	20.2" (513mm)
Crated	27" (686mm))

**OVEN INSTALLATION CLEARANCE REQUIREMENTS**

Kitchen Environment	Low temp.	High temp.*
Left Side & Back	2" (50mm)	2" (50mm)
Right (control) Side	2" (50mm)	16" (400mm)

\* includes heat sources (fryers, hot plates, etc) placed on the control side of the combi

For servicing, Blodgett recommends maintaining at least 16" (400 mm) between the control side and walls or non moveable equipment.

