

Project:	
Model #:	
Item #:	
Available W/H:	Qty:
Approval:	
AIA #:	SIS #:
CSI Section 11400	

Prep Table + Work Station - Drawers / Front Breathing Airflow

Food Prep Tables - Drawers
 Super Deluxe Series

FEATURES & BENEFITS

Self-Cleaning Condenser

The accumulation of dust in the condenser can cause the failure or breakdown of refrigerators. Refrigerators run normally until they reach a certain level of accumulation. At some point, when they are over the limit, their performance drops quickly resulting in damage to, or disposal of the stored products inside. The Self-Cleaning Condenser device keeps the condenser clean and prevents system failure by automatically brushing daily.

Digital temperature control & monitor system

Keeps food products safe by maintaining constant temperatures. External digital display allows for easy monitoring.

Front Breathing airflow

Front Breathing airflow is designed to draw in air and discharge from the front, allowing units to run at high efficiency in tight spaces and eliminates the need for surrounding clearances.

Hydrocarbon refrigerants (R-290)

With innovative and eco-friendly technology, Turbo Air brings you hydrocarbon refrigerators designed to meet DOE's Energy Conservation Standards in 2017 and to use EPA's SNAP Program approved HC refrigerants. Hydrocarbon refrigerants do not deplete the ozone layer and have very low contribution to global warming (ODP-0, GWP-3).

Cold Bunker system

Our innovative forced air system allows cold air to flow all around the food pan area, covering not only underneath the pan, but also the front, top and the rear. This unique air flow creates a cold air-shield around the pan, which maintains the food temperature at under 41°F (NSF requirement) even when the lids are opened. In addition, the compartment isolates pans from the reach-in area to prevent food spillage.

Stainless steel cabinet construction

The Turbo Air Super Deluxe model boasts a stainless steel interior (ABS door liner) and exterior (galvanized steel back & bottom). It guarantees the utmost in cleanliness and long product life. The Super Deluxe adds a touch of style to the most refined setting.

High-density polyurethane insulation

The entire cabinet structure and solid doors are foamed-in-place high density, CFC free polyurethane insulation.

Insulated pan cover

9-1/2" deep, 1/2" thick high-density Polyethylene cutting board included with convenient side rail

Each top drawer accommodates up to 6" deep, one (1) full size pan with three (3) 1/6 size pans or three (3) 1/3 size pans with three (3) 1/6 size pan or nine (9) 1/6 size pans. And each bottom drawer accommodates up to 6" deep, one (1) full size pan or two (2) 1/3 size pans with two (2) 1/6 size pans or six (6) 1/6 size pans (drawer pans not included)

Model : TST-60SD-18M-D2L-FB-N TST-60SD-18M-D2L-FB-N-LW



TST-60SD-18M-D2L-FB-N



TST-60SD-18M-D2L-FB-N-LW

Patented Self-Cleaning Condenser



This product is equipped with a fine mesh filter to the front of the condenser to catch dust, and a rotating brush that moves up and down daily to remove excess buildup outward and away.

Refrigerator holds 33°F ~ 39°F for the best in food preservation

- TST-60SD-18M-D2L-FB-N: Right work station
- TST-60SD-18M-D2L-FB-N-LW: Left work station



Model	Swing Doors	Drawers	CU./FT.	#of Shelves	#of Pans	HP	AMPS	Crated Weight (lbs.)	L x D x H† (inches)
TST-60SD-18M-D2L-FB-N(-LW)	1	2	14.8	1	18	1/5	8.9	362	60 1/4 x 33 1/2 x 39 5/8

Model : TST-60SD-18M-D2L-FB-N(-LW)

ELECTRICAL DATA	
Voltage	115/60/1
Plug Type	 NEMA 5-15P
Full Load Amperes	8.9
Compressor HP	1/5
Cord Length (ft.)	10
Refrigerant	R-290
DIMENSIONAL DATA	
Ext. Length Overall (in.)	60 1/4 (1530mm)
Ext. Depth Overall (in.)*	33 1/2 (850mm)
Ext. Height Overall (in.)†	39 5/8 (1006mm)
# of Doors	1
# of Drawers	2
# of Shelves	1
# of Pans	18
# of Hood	1
Shelf Size (L x D)	27 x 17
Net Capacity (cu. ft.)	14.8
Net Weight (lbs.)	331
Gross Weight (lbs.)	362

Design and specifications subject to change without notice.
Actual shipping weight may differ due to extra packing materials for product protection.
* Depth does not include 3" for cutting board.
† Height does not include 4-1/2" for caster height.

■ WARRANTY : 5 Year Parts and Labor Warranty 7 Year Compressor Warranty

■ STANDARD FEATURES

- Anti-corrosion coated evaporator
- Self-contained system
- 4" dia. swivel casters with locks on the front set
- 1/6 size, 4" deep condiment pans included (top of cabinet)

■ OPTIONAL ACCESSORIES

- 1" caster, 1/2" diameter & 13 TPI: S28R813660 (non-brake)
- 2.5" caster, 1/2" diameter & 13 TPI: 30265H0100 (non-brake), 30265H0200 (w/ brake)
- 5" caster, 1/2" diameter & 13 TPI: M726500100 (non-brake), M726500200 (w/ brake)
- Leveling leg, 1/2" - 13 TPI x 1.54": LFM1213566
- 6" ABS plastic leg: 30221M0200
- 6" stainless steel leg: 30221M0600
- Additional stainless steel shelf: M607800100
- Removable food covers: RCT-48-18/72-30-L
- Single overshelf, stainless steel, 60-3/8" W: TSOS-5S
- Double overshelf, stainless steel, 60-3/8" W: TSOS-5R-T
- Clear lid: CL-48-18

Ver.20241024

PLAN VIEW

(unit : inch)

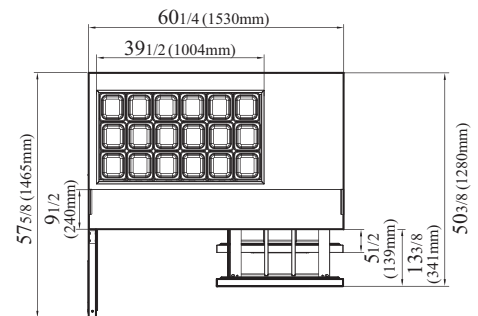

TST-60SD-18M-D2L-FB-N
TOP VIEW

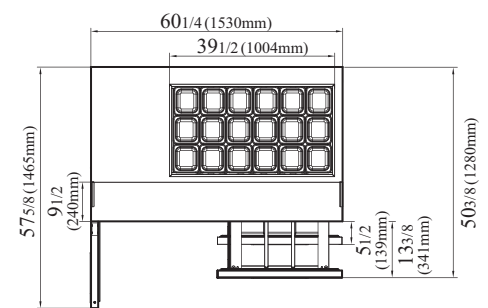

TST-60SD-18M-D2L-FB-N-LW
TOP VIEW

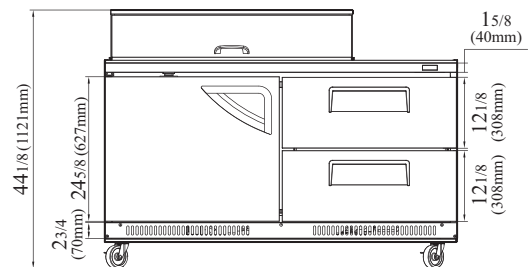

TST-60SD-18M-D2L-FB-N
FRONT VIEW

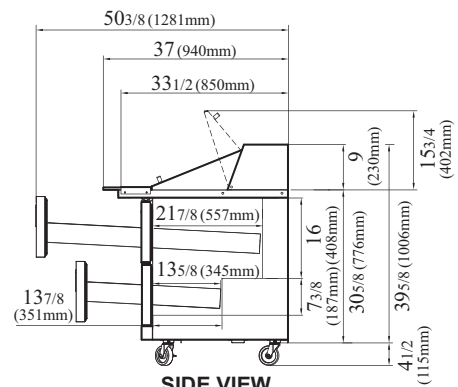

SIDE VIEW



- Turbo Air: 800-627-0032
- Radiance: 800-500-3519
- Warranty: 800-381-7770
- AC: 888-900-1002



Continued product development may necessitate specification changes without notice.