

MANTEGNA 350 BS TOP ROSSA - 14"

Straight-feed slicer, red finish, for cured meats

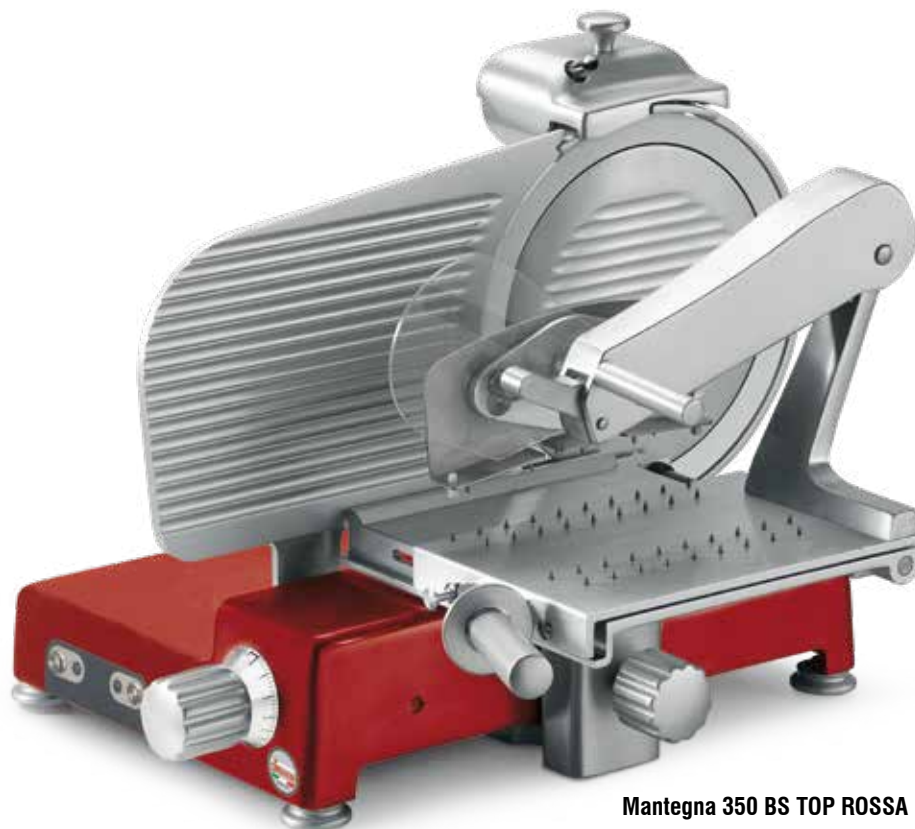

Mantegna 350 BS TOP ROSSA

- 14" high-quality, heavy-duty straight-feed cooked meat slicers
- Designed for precise slicing of all kinds of cooked and cured meats
- Fitted with a double-feed carriage with a double articulating clamping arm holding any product firmly in place
- The TOP version provides even higher durability in terms of reduced maintenance costs with:
 - all knobs, handles, dials and feet in aluminum
 - a fully sealed and waterproof IP 67 switch, with stainless steel on/off buttons
 - no volt release prevents inadvertent reactivation after a power outage
 - complete stainless steel drive shaft assembly

Features

Technical

- The special carriage allows you to slice any kind of cooked meat.
- The sharpener assembly is made entirely from aluminum, no plastic that may break with heavy use.
- The tie rod assembly and all screws are made of stainless steel for longer life.
- The slide shaft is made of ground, chromed steel for a smoother operation.
- The high-quality bushings and ball bearings are self-lubricating.
- The dial thickness control cam system allows for an always precise cut.

Safety

- A safety cover is placed under the motor and the electrical components.
- The clamping arm features an exclusive heavy duty plastic protection to keep operator's hand at a safe distance from the blade while operating slicer.

Sanitary

- Easy to clean aluminum alloy construction does not crack or stain.
- The screws are stainless steel and resist wear and oxidation.
- The carriage and the center plate are quickly removable without tools.

Specifications

Operation:	Straight Feed.
Construction:	Polished, anodized aluminum alloy.
Knife:	14" (350 mm), one piece, chromium plated 100Cr6 forged carbon steel blade.
Sharpener:	Built-in, removable, two stone dual action.
Slice thickness:	Infinitely variable up to 1 ^{3/16"}
Motor:	0.5 Hp (410 W), belt driven, fan cooled.
Electrical:	120V AC, 60Hz, 2 Amp. (220V, 50Hz available on request).
Plug and Cord:	Attached, flexible, 3 wire SJTO AWG 18, 6'4" long, NEMA 5-15 P
Controls:	ON/OFF stainless steel keypad, IP 67 waterproof protection. No voltage release.



Certified to UL Standard 763
and NSF Standard 08
Certified to CSA Standard C22.2



Removable food pusher

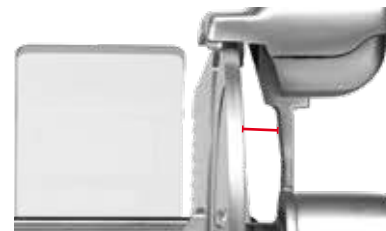

Increased gap between blade and machine body

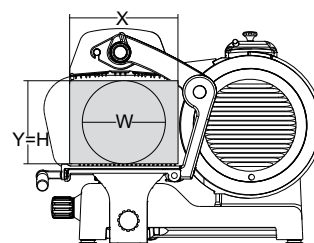
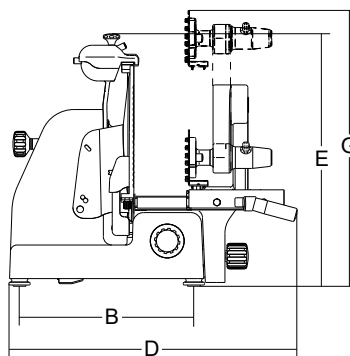
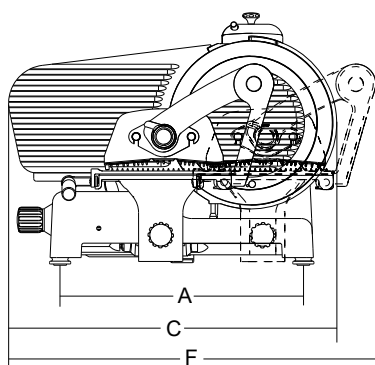

	Ø Blade	Motor	Cut thickness	Blade rpm	Carriage stroke	Hopper	A	B	C	D	E	F	G	X	Y	H	W	Net weight	Shipping	Gross weight
	mm/inch	watt/Hp	inch.	rpm	inch.	inch.	inch.	inch.	inch.	inch.	inch.	inch.	inch.	inch.	inch.	inch.	inch.	lbs.	inch.	lbs.
Mantegna 350 BS TOP ROSSA	350/14"	410-0,55	13 ⁹ / ₁₆ "	216	12 ⁹ / ₁₆ "	11 ¹³ / ₁₆ " x 10 ⁵ / ₈ "	18 ⁷ / ₁₆ "	13 ⁵ / ₁₆ "	26"	23 ⁵ / ₈ "	20 ⁷ / ₈ "	29 ¹ / ₂ "	28 ¹ / ₈ "	10 ⁵ / ₈ "	10 ¹ / ₁₆ "	10 ¹ / ₁₆ "	10 ¹ / ₁₆ "	84	30" x 25" x 29"	117

