





## Technical Data

Gas Inlet Size	1/2 Inches
Number of Fry Baskets	2 Fry Baskets
Number of Fry Pots	1 Fry Pot
Power Type	Natural Gas
Split Pot	Without Split Pot
Temperature Range	200 - 400 Degrees F
Total BTU	150000 BTU
Type	Gas Floor Fryers

## Plan View

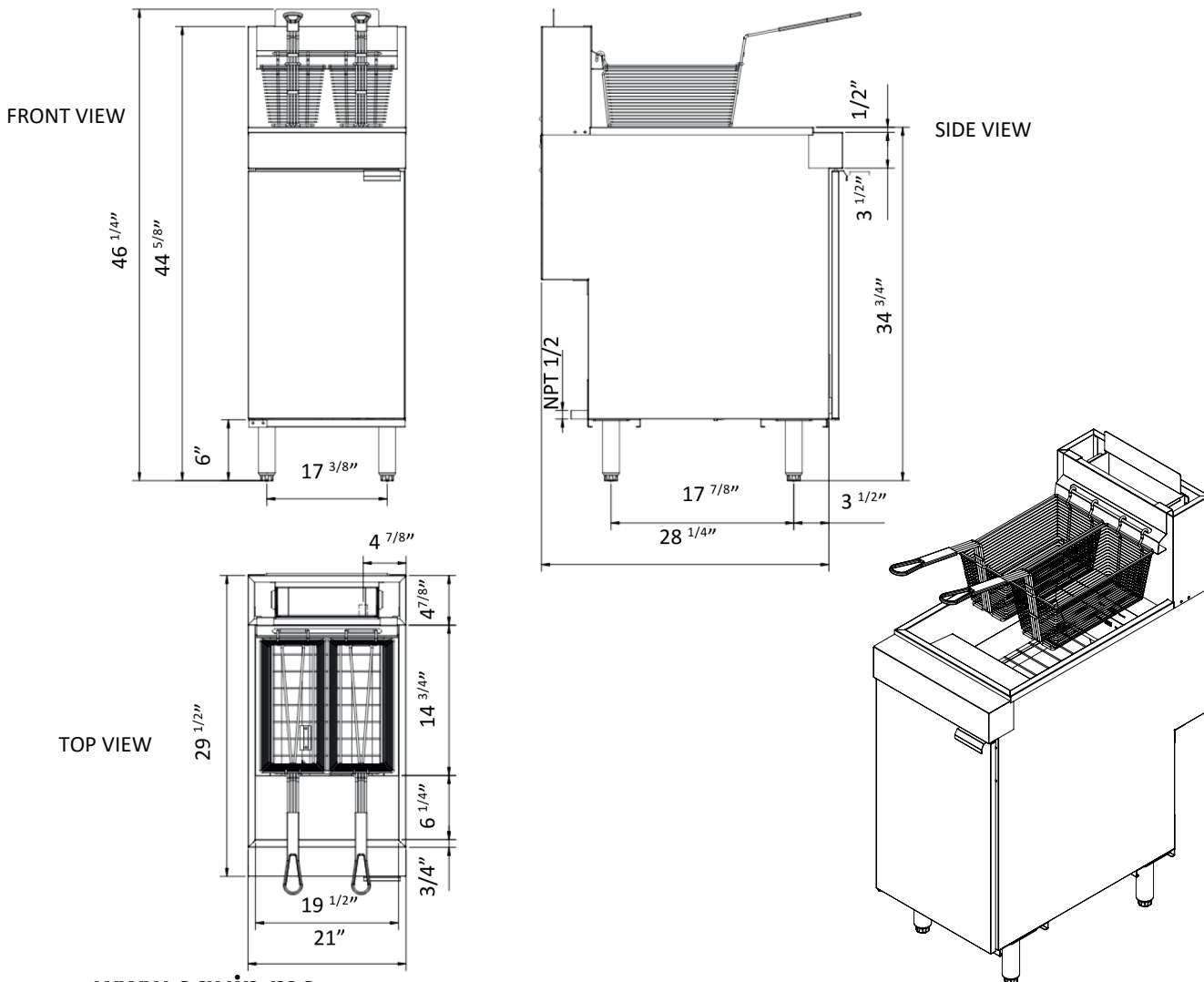

[www.equip.me](http://www.equip.me)



## Notes & Details

### Gas Fryer - 70lb.

Introducing our high-performance Gas Fryer, meticulously designed to elevate your frying experience. Boasting a vertical cast iron burner delivering a robust 30,000 BTU/hr each, this fryer ensures swift and efficient cooking. Crafted with a stainless steel vat, available in four versatile models, and supported by 6" stainless steel adjustable heavy-duty legs, it guarantees durability and stability.

Its innovative tube design, coupled with baffles inside, maximizes heat transfer, ensuring even and consistent cooking. With a continuous pilot for hassle-free ignition of the main flame, and a chromed basket featuring a plastic-coated handle for safety and convenience, this fryer prioritizes ease of use.

Designed with a spacious cold zone to prevent food particles from scorching at the bottom, and equipped with a Robertshaw control system for optimal performance, it promises reliability with every use. Experience prompt temperature recovery for irresistibly crispy fries, thanks to its efficient design.

For added convenience, it features a 1-1/4" drain cock for effortless oil drainage, while the thermostat allows precise temperature adjustments ranging from 93°C/200°F to 204°C/400°F. Safety is paramount with a 450°C/232°F hi-limiter ensuring peace of mind during operation.

Optional castors provide mobility for flexible positioning in your kitchen setup. Elevate your frying game with our Gas Fryer, where performance, durability, and safety converge for exceptional culinary results.

Capacity - 70lb.

**Instructions and images in this manual are only for reference and may differ from the actual product. Launch the E-Manual.**