

Refrigeration Equipment 2-Door Under Counter Refrigerator 61" Long 32" Tall

ITEM # _____

MODEL # _____

NAME # _____

SIS # _____

AIA # _____



738333 (KCHUC60R-32)

2-DOOR UNDER COUNTER
REFRIGERATOR 61" LONG
32" TALL

Short Form Specification

Item No. _____

2-door refrigerator counter top, 32 inch tall, with exterior back panel, exterior bottom panel, and exterior top panel in galvanized steel, exterior side panel in 430 stainless steel; interior back, top and bottom panels in 304 stainless steel. Fin & tube condenser to improve the performances in high temperature environments. Automatic Defrost Cooling System and temperature control. Vinyl heavy duty adjustable, easy to handle and clean shelves.

External temperature display.

R600a gas in refrigeration circuit.

ETL Safety and Sanitation certified.

3/5 Years warranty.

Main Features

- External temperature display.
- Removable gasket for easy cleaning operations.
- Fin & Tube Condenser improves performance in high temperature environments.
- Automatic Defrost Cooling System provides worry-free performance.
- Electronic Temperature Control, quick and simple to set, with control display for easy monitoring.
- Heavy duty Vinyl coated steel shelves.
- Cabinet completely insulated with high density polyurethane for low environmental impact.
- ADA Height Compliant

Construction

- Stainless steel interior and exterior, durable and easy to clean for daily commercial use.
- Self-closing door with 90-degree stay-open feature.
- Heavy duty casters.
- Pre-wired heavy duty power cord.
- Heavy duty door hinges.
- Magnetic gasket removable without tools for easy cleaning.

Sustainability

- CFC and HCFC free (ecological refrigerant type: R600a).
- High efficiency components to minimize the energy consumption still guaranteeing the highest performances.

Optional Accessories

- 1 ADJUSTABLE FOOT PNC 206445
- Drawer Kit for 60" Mega Top & Undercounter PNC 880617

APPROVAL: _____

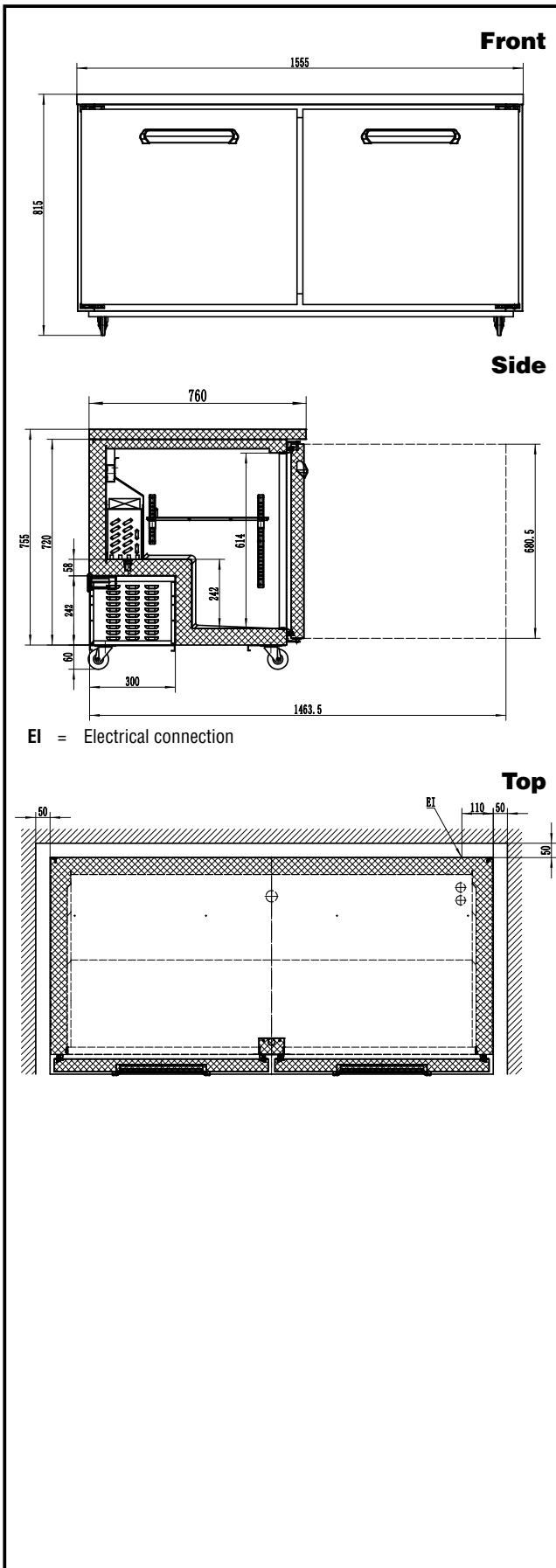

Electric

Supply voltage:	738333 (KCHUC60R-32)	115 V/1 ph/60 Hz
Electrical power, max:		0.31 kW
Plug type:		USA NEMA 5-15P

Capacity:

Gross capacity:	15.5 cu.feet
Number and type of grids (included):	2 - 703x425

Key Information:

Door hinges:	Right Side
Capacity:	15.5 cu.ft.
External dimensions, Width:	61 1/4" (1555 mm)
External dimensions, Depth:	29 15/16" (760 mm)
External dimensions, Height:	32 1/16" (815 mm)
Number and type of doors:	2 Full
Internal Dimensions (depth):	22 13/16" / (580 mm)
Internal Dimensions (height):	23 1/2" / (597 mm)
Internal Dimensions (width):	22 1/4" / (565 mm)
Shipping height:	34 13/16" (885 mm)
Shipping weight:	280 lbs (127 kg)
Shipping volume:	39.87 ft ³ (1.13 m ³)
Type of external material:	Stainless Steel
Type of internal material:	Polystyrene
Warranty:	3 / 5 years
Approvals	ETL C&US;ETL SANITATION

Refrigeration Data

Compressor power:	1/8 hp
Operating temperature min.:	32 °F
Operating temperature max.:	41 °F
Condenser type:	Fin & tube
Defrost type:	Auto Defrost

Sustainability

Current consumption:	3 Amps
Refrigerant type:	R600a
Refrigerant weight:	80 g

