



Project Name: _____

Location: _____

Item #: _____

Qty: _____

Grista Reach-In Refrigerator, 2 Door - 48 Cu Ft, 54"

GRRF-2D



A staple in professional kitchens, the Grista 2 Door Reach-in Refrigerator is designed to provide easy access to refrigerated food and ingredients. This commercial reach-in refrigerator is constructed of a durable, easy-to-clean 430 series stainless steel exterior and painted white aluminum interior. The two-door reach-in fridge has a storage capacity of 48 cubic feet, offering ample space for storing ingredients like meats, dairy and vegetables. The double-door reach-in refrigerator comes with six epoxy-coated corrosion-resistant shelves.

FEATURES AND CONSTRUCTION

- Easy to clean 430 series stainless steel exterior and painted white aluminum interior
- Storage capacity of 48 cu ft (1359 L)
- Includes 6 epoxy coated corrosion resistant shelves with 90 lb capacity each
- Two self-closing solid doors with stay open feature beyond 90°
- Front digital temperature controller with LED display
- Incandescent interior lighting makes it easy to find and access stored items
- Digital temperature control range of 33°F to 41°F
- Bottom mounted condensing unit positioned for easy maintenance
- Preprogrammed digital control featuring auto defrost cycle
- Foamed in place insulation helps provide strength while helping to maintain internal temperature

ELECTRIC

115V / 60Hz / 1Ph
Cord Length (Inches): 98.40"
Plug Type: NEMA-5-15P
Cord set included

NEMA 5-15P



3RD PARTY APPROVALS

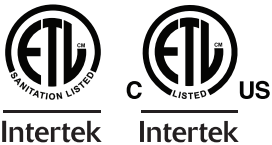

WARRANTY (USA / CANADA)

2 Year Warranty on Parts & Labor, 5 Years on Compressor
Contact Admiral Craft Equipment for details at 1-877-672-7740



NOMINAL STORAGE CAPACITY

Cubic Feet: 46.7 cu. ft.

TEMPERATURE

Holding Temperature (Fahrenheit): 33° - 40°

These models are designed to operate in an environment where temperature and humidity do not exceed 75°F (24°C) and 55% relative humidity



Grista Reach-In Refrigerator, 2 Door - 48 Cu Ft, 54"

GRRF-2D

FRONT

SIDE

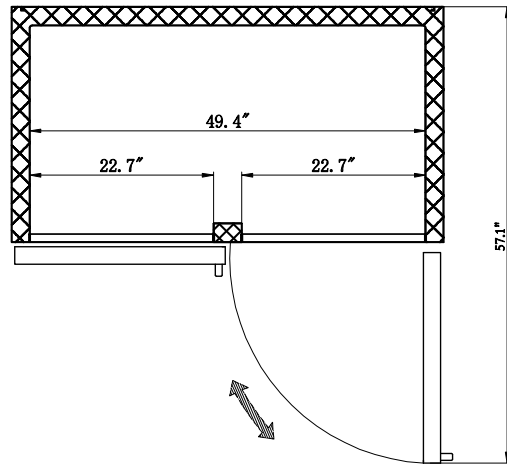
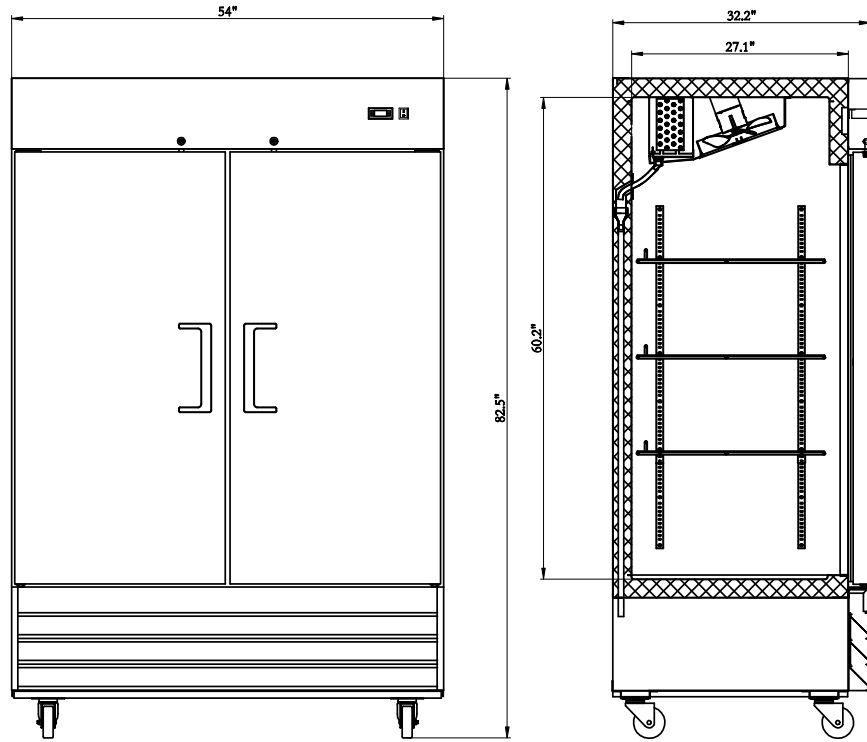

TOP

Reach-In Refrigerators

Doors	Shelves	Amps	HP	Refrigerant	Dimensions	Item Weight lbs	Shipping Weight lbs
2	6	6.2A	0.75	R290	54" x 32.2" x 82.5"	446.6	530.0

Due to periodic changes in designs, methods, procedures, policies and regulations, the specifications contained in this document are subject to change without notice. While we exercise good faith efforts to provide information that is accurate, we are not responsible for errors or omissions in information provided or conclusions reached as a result of using the specifications. By using the information provided, the user assumes all risks in connection with such use.