

6 Drawer Ambient Dough Cabinet

- Prep table storage companion
- Perfect for pizza dough or to store additional utensils, cutting boards or trays
- Features 6 storage drawers
- 4 casters (2 locking) included for easy mobility



UCCATP

Top

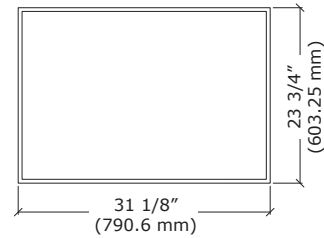

Front

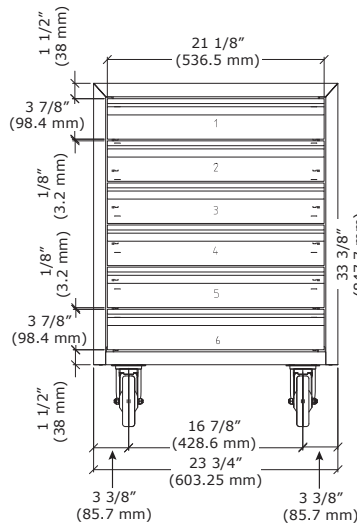

Side

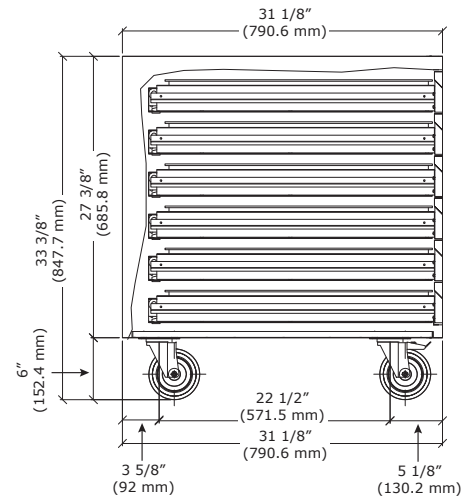

Model	Description	Shipping Weight
UCCATP	6 Drawer Ambient Dough Cabinet	132 lb

Specifications

UCCATP dimensions: 33 7/8" H X 23 3/4" W X 31 1/8" D

AISI 304 stainless steel interior and exterior

Holds up to 6 dough boxes (25 5/8" W X 18" D X 3 1/4" H)

NSF/ANSI Standard 7 compliant

Commercial Warranty

3 Year (parts & labor) / 5 year sealed system (parts)

See complete warranty for details

