



Responsive. Reliable.

Project Name/No: _____ Item No: _____

Quantity: _____ SIS#: _____ AIA/CSI#: _____

Portable Waste Oil Caddy

GOC



The versatile **GOC Waste Oil Caddy** provides foodservice operators a means to safely remove used cooking oil from fryers and move it to a designated disposal site.

- Manually operated pump ... not bound by power cords and electrical outlets.
- Pump operates in either direction ... turn one direction to discharge from tank ... turn crank in opposite direction for suction.
- Durable stainless steel construction.
- Large 8" wheels makes maneuvering and handling easy when full.
- Capacity to hold approximately 80 lbs of waste oil.

Portable, flexible and efficient; saving time and money. The perfect way to handle your waste cooking oil.

Design Features:



Equipped with a Sight Glass which provides an easy to see indication that the oil level is approaching full, preventing over-filling and spillage.

Sight Glass

Capacity:

Enough volume to hold waste oil from two (2) medium size fryers (approx. 80 lbs).

Hinged Lid w/Latch:

Holes in lid are rimmed with rubber grommets, providing a receptacle for the Wand of the

Discharge Hose from the fryer when pumping waste oil into tank.

Also, for storing the Oil Caddy Hose Wand, allowing oil residue to drain into tank rather than being dripped onto the floor.



GILES Food Service Equipment • ISO 9001 Registered

PO Box 210247; 2750 Gunter Park Drive W; Montgomery, AL 36109 USA

334.272.1457 • Fax 334.239.4117 • Toll Free 800.554.4537 (US/Canada Only) • www.gfse.com • Email: services@gfse.com

Printed in USA, Form 65776 (Rel.Date: Apr.2003, Rev. Date: Sep.2010, Rev. C

Portable Waste Oil Caddy GOC

Project Name/No: _____ Item No: _____

Quantity: _____ SIS#: _____ AIA/CSI#: _____

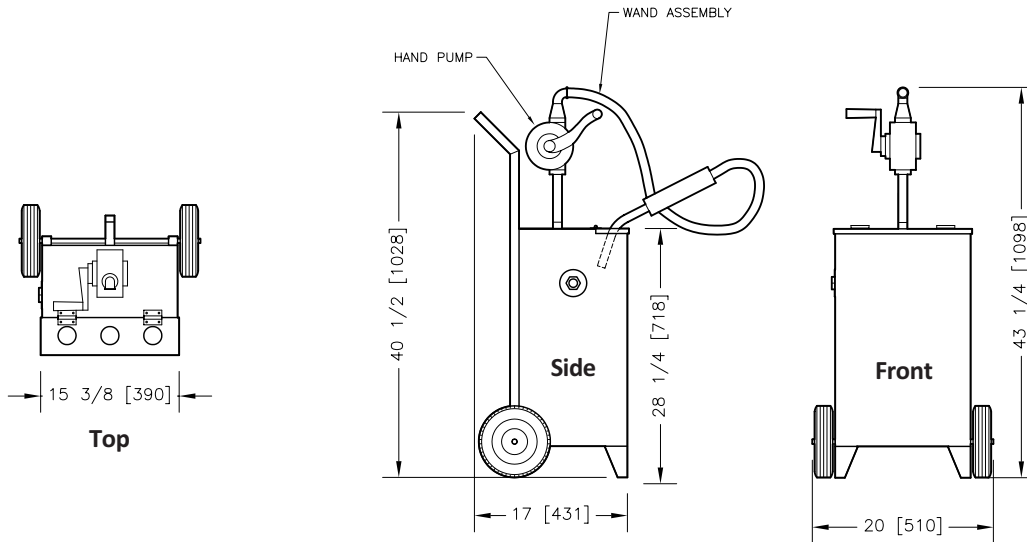

Inches [mm]

Specifications

Construction: Tank - 16 Ga & 18 Ga stainless steel ... Handle - 16 Ga, 1" Sq, stainless steel tube

Dimensions:

Width	Depth	Height	Floor Space
20" [508 mm]	17" [432 mm]	43-1/4" [1099 mm]	2.4 sq.ft [0.2 sq.m]

Operating Temperature:

Max. Temp = 350°F [177°C]

Min. Temp = 100°F [38°C] to 200°F [93°C]

(Designed to handle ONLY warm filtered oil)

Capacity:

Holds up to 80 lbs [36 kg] of waste cooking oil.

Shipping Specifications:

Width	Depth	Height	Cube	Crated Weight
21" [534 mm]	18" [457 mm]	46" [1169 mm]	10 cu ft [0.3 cu m]	67 lbs [137 kg]

How To Specify

1. Ordering Options

Specify part number from the following:

✓	Model	Item Number
	GOC	79187

2. Shipping

Specify preferred shipping method

Typically ships via Parcel Service.

GILES Food Service Equipment

2750 Gunter Park Drive West • Montgomery, AL 36109 USA
 Phone: 334.272.1457 • Toll Free: 800.554.4537 • Fax 334.239.4117
 Website: www.gfse.com • Email: services@gfse.com

Product specifications and/or designs are subject to changes without notice. Such revisions do not entitle the buyer to corresponding changes, improvements, additions or replacements for previously purchased equipment.

Printed in USA, Form 65776 (Rel.Date: Apr.2003, Rev. Date: Sep.2010, Rev. C