



BEVERAGE-AIR

Project: _____	AIA#
Item: _____	
Location: _____	SIS#
Approved: _____	

HFS3HC TOP MOUNT REACH-IN FREEZER

HORIZON TOP MOUNT REACH-IN

HFS3HC Half-Solid Triple Door Reach-In Freezer

Hydrocarbon Series

MODEL:**HFS3HC-1HS**

7 Year Parts/Labor Warranty
7 Year Compressor Warranty

CABINET CONSTRUCTION

- Exterior is stainless steel front and continuous coil coated sides
- Stainless steel interior
- Full electronic control
- Expansion valve technology
- One piece grille
- LED interior light
- Self-closing door with 120° stay-open feature, on cam-lift hinges
- Field reversible doors
- Door locks
- Snap-in magnetic gaskets for positive door seal
- Nine (9) heavy-duty epoxy coated wire shelves
- 6" Heavy-duty casters, two (2) with brakes
- 8' Cord and plug (see electrical data for details)

OPTIONS & ACCESSORIES

- Tray slide pair, 1 tray slide set for (1) 18" x 26" or (2) 14" x 18" pans (A)
- Stainless steel universal tray slide pair, 1 tray slide set for (1) 18" x 26" or (2) 14" x 18" pans (AC)
- Tray slide kit #4 (19 sets per half section)
- Additional epoxy shelves
- Shelf clips
- Stainless steel breaker
- 6" Legs seismic/flanged
- 3" Casters
- Remote option* (see note on back page)

REFRIGERATION SYSTEM

- Uses environmentally friendly, energy efficient R290 refrigerant, and meets all regulatory requirements for CARB, SNAP, DOE & more
- Hot gas condensate evaporator
- Adaptive defrost
- Epoxy coated evaporator coil
- Freezer capable of maintaining product temperature down to -10°F



 Please verify qualifying units by visiting:
www.energystar.gov/cfs

3779 Champion Blvd., Winston-Salem, NC 27105
 1-888-845-9800 Fax: 1-336-245-6453
 Beverage-Air.com Sales@bevair.com



BEVERAGE-AIR

MODEL	HFS3HC-1HS
EXTERNAL DIMENSIONAL DATA	
Width Overall	78"
Depth Overall with Handle	33 5/8"
Height Overall	85"
Number of Doors	6
Depth with Door Open 90°	55 1/8"
Door Opening (in)	21 5/8" x 29 5/8"
INTERNAL DIMENSIONAL DATA	
NET Capacity (cubic ft.)	69.1
Internal Width Overall (in)	74"
Internal Depth Overall (in)	25 7/8"
Internal Height Overall (in)	62"
Number. of Shelves	9
ELECTRICAL DATA	
Full Load Amperes	13.2
Voltage	115/60/1
Nema Plug (8' cord)	5-15P
REFRIGERATION DATA	
Horsepower	(2) 3/4
Capacity (BTU/Hr)	3854
Heat Rejection (BTU/Hr)	5781
Charge (lbs/grams/ounces)	0.2866 / 130 / 4.59
SHIPPING DATA	
Gross Weight - Crated	744 lbs
Height - Crated	88"
Width - Crated	81"
Depth - Crated	36"

*NOTE: Remote units are field wired and come with 6" legs.
Refrigerant must be specified at time of order.

We reserve the right to change specifications and product design without notice. Such revisions do not entitle the buyer to corresponding changes, improvements, additions or replacements for previously purchased equipment. Dimensional tolerances +/- 1/4". Metric dimensions (MM).

Top Mount Reach-In Freezer Model: HFS3HC-1HS

Model Views

Required Clearance: Top 12", Rear 3", Sides 0"

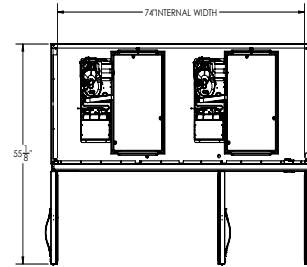

PLAN VIEW

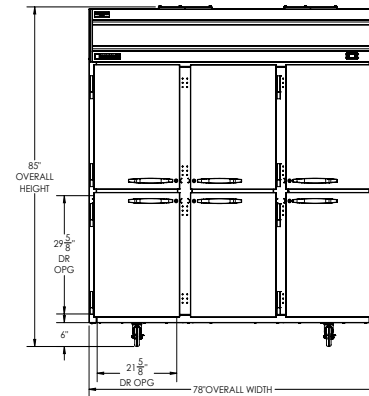

ELEVATION VIEW

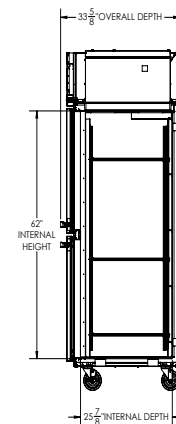

SIDE VIEW

ELECTRICAL CONNECTION



115/60/1
NEMA 5-15P

Unit pre-wired at factory and include 8' long cord and plug set.

